

Betts Industries, Inc.

Warren, PA 16365

Phone: 814-723-1250

# **MAINTENANCE MANUAL**

## **FOR**

# **8" SURGE SUPPRESSION**

# **RELIEF VALVE**

**Section 1: Identification of 8" Surge Suppression Relief Valve**

**Section 2: Maintenance and Testing for 8" Surge Suppression Relief Valve**

**Section 3: Disassembly of 8" Surge Suppression Relief Valve**

**Section 4: Assembly of 8" Surge Suppression Relief Valve**

**8/14/98**

## SECTION 1: IDENTIFICATION OF SURGE SUPPRESSION RELIEF VALVE

Betts Surge Suppression Relief Valves (SSRV's) meet or exceed all U.S. DOT requirements for primary pressure relief valves on DOT406 cargo tanks as contained in 49CFR178.345-10 and 49CFR178.346-3 of the Code of Federal Regulations. The Betts Surge Suppression Relief Valve is able to withstand a brief pressure surge (per TTMA RP NO 81) and contain the lading to **zero leakage**. See figure 1 for identification criteria.

Betts SSRV's protects the cargo tank from rupture due to over-pressurization caused by overfilling or fire and is, therefore, crucial to the safe operation of the tank. In order to maintain your Betts SSRV's in proper working condition, the following procedures outlined in this manual must be followed.

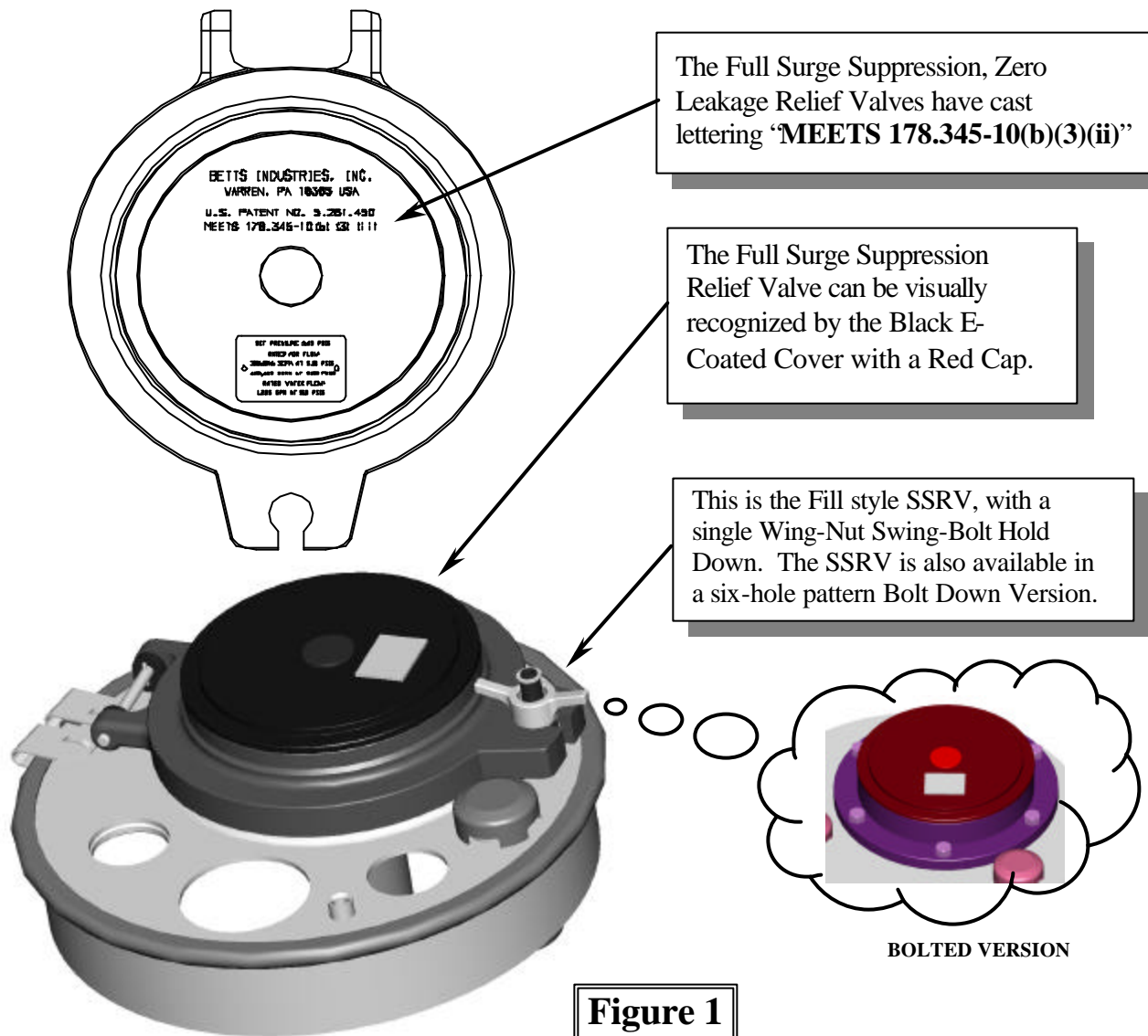

## SECTION 2: MAINTENANCE AND TESTING FOR SURGE SUPPRESSION RELIEF VALVE

- A. **U.S. DOT Requirements:** This manual refers to the DOT regulations. *However, it does not take the place of the Code of Federal Regulations.* A current copy of the Code of Federal Regulations should be reviewed and followed to insure the requirements are met for each case.

There are three basic tests/inspections mandated by 49CFR Part 180 for MC306 and DOT406 cargo tanks.

Test/Inspection	Interval Period	Code Paragraph
External Visual Inspection	1 year	49CFR180.407(d)
Leakage Test	1 year	49CFR180.407(h)
Pressure Retest	5 year	49CFR180.407(g)

1. **External Visual Inspection:** As part of the annual external visual inspection, 49CFR180.407(d)(3) requires that all pressure relief valves, be visually inspected for any corrosion or damage which might prevent the valve from functioning. If the cargo tank is used to haul product that is corrosive to the relief valve, the valve must be removed from the cargo tank for inspection and bench testing.

**Note: Betts recommends that the external visual inspection of vents be performed monthly.**

- 1.1. Visually inspect all external surfaces of the manhole and Surge Suppression Relief Valve (SSRV) for signs of corrosion or damage. For Fill Style SSRV this requires unscrewing swingbolt and opening SSRV. For Bolted Style SSRV this requires unbolting and removing from manhole.  
**NOTE:** Review section three steps 1 - 3 for proper procedures for SSRV removal.

- 1.1.1. Clean and inspect the bottom side of the SSRV for signs of damage, corrosion, or product gumming that could effect the operation of the Relief Valve. See figure 2.  
1.1.2. Closely inspect the *Cylinder* for any damage or dents. Also, insure *Cylinder* is threaded tightly to the *Cover*.  
**NOTE:** Review section three steps 1 - 3 for proper procedures for SSRV removal.  
1.1.3. Inspect *Normal Vent* and clean as necessary.

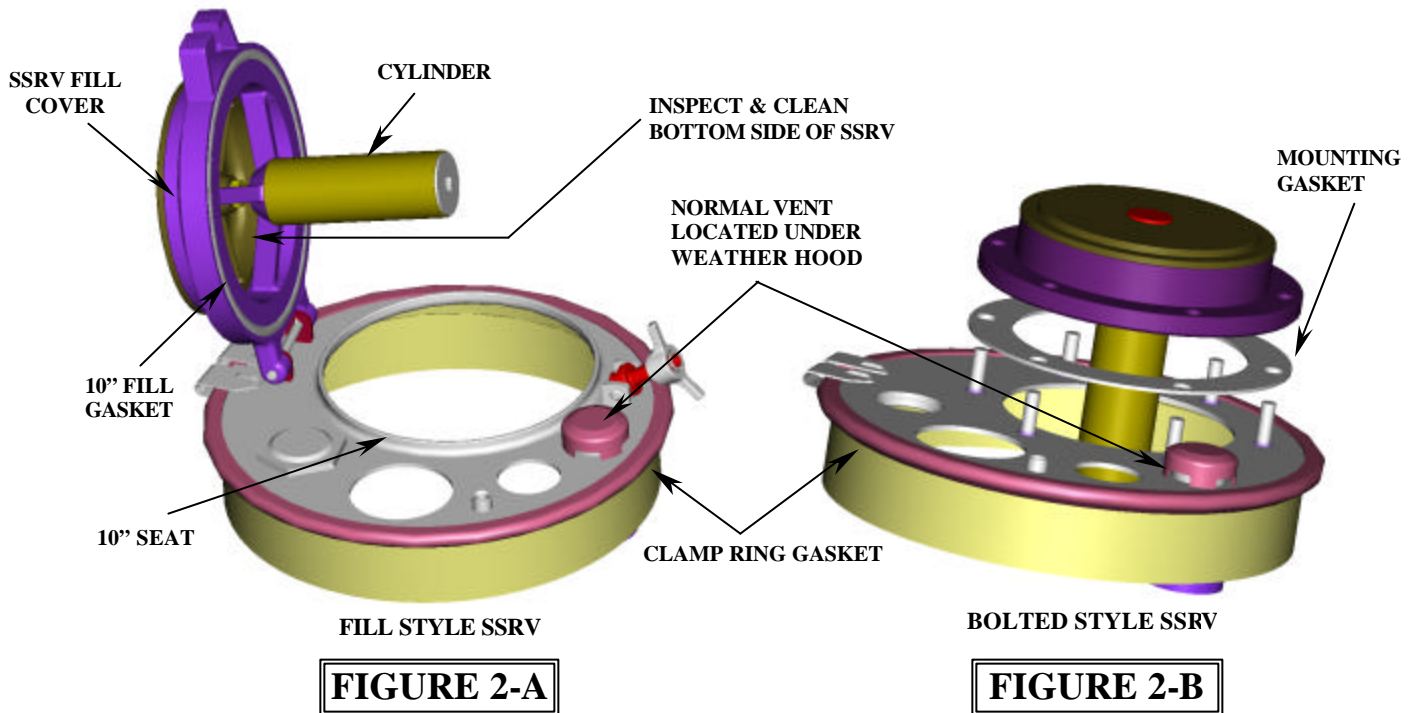

# Betts Industries, Inc.

Warren, PA 16365

Phone: 814-723-1250

- 1.1.4. Inspect the *Clamp Ring Gasket* for evidence of product seepage. Replace any gaskets where seepage is detected.
- 1.1.5. For the Fill Style SSRV, inspect the *10" Seat* for damage or corrosion and inspect the *10" Fill Gasket* for signs of wear or degradation. Replace any gaskets where seepage is detected.
- 1.1.6. For the Bolted Style SSRV, inspect the *Mounting Gasket* for signs of wear or degradation. Replace any gaskets where seepage is detected.

**NOTE:** If any corrosion or damage to the SSRV or manhole is observed, it must be repaired and successfully bench tested prior to returning to service. Refer to 3.2 for SSRV bench test procedure.

2. **Leakage Test:** 49CFR180.407(h) requires tanks to be tested annually at 80 % of the tank design pressure or MAWP, whichever is marked on the tank certification or specification plate. All tank components must remain in place during this test, except any re-closing pressure relief valve with a set pressure less than the leakage test pressure must be removed or rendered inoperative during the test. Betts Normal Vents, therefore, must be removed during the leakage test.
  - 2.1. Remove *Normal Vent* from manhole cover and plug opening with Betts Plug No. 3013.
  - 2.2. Apply test pressure in accordance with 49CFR180.407(h)
  - 2.3. Inspect all gasket joints on SSRV and manhole for leaks. Replace damaged or worn gaskets as required and retest the unit.
3. **Pressure Retest:** As part of the pressure retest, 49CFR180.407(g)(ii)(A) requires that all re-closing pressure relief valves be removed from the tank for inspection and bench tested to verify that the relief valve is functioning properly. The pressure retest and the relief valve bench test must be performed at least every five years.

**Note: Betts recommends that the Surge Suppression Pressure Relief Valves be bench tested annually.**

### 3.1. Pressure Retest Procedures:

- 3.1.1. 49CFR180.407(g)(1)(vii) requires that all closures, except for pressure relief valves, with a set pressure less than the tank test pressure must be in place during the test.
- 3.1.2. Manholes must remain in place during pressure test.
- 3.1.3. Remove *Normal Vent* from manhole cover and plug opening with Betts Plug No. 3013.
- 3.1.4. Fill Style SSRV's must remain in place so the 10" fill gasket is subjected to test pressure.
  - 3.1.4.1. Install Betts SSRV Pressure Test Clamp (part no. 6697) to hold SSRV closed during test. (Refer to manual included with clamp for installation instructions.)
- 3.1.5. Bolted Style SSRV's should be removed from the manhole and the opening blanked off with a blind flange (part no. 3939)
- 3.1.6. Betts Push and Air Operated Vapor Recovery Valves remain in place during the test.  
**NOTE: If vapor recovery valves from other manufactures are installed, refer to the manufacturers' instructions to see if they should be removed.**
- 3.1.7. After preparing the rest of the tank, perform the pressure test in accordance with the regulations. Inspect all parts of manhole assembly for leakage. Repair or replace parts as required.
- 3.1.8. Remove all clamps or plugs from relief valve immediately after test is completed.

### 3.2. Bench Test Procedure for SSRV

- 3.2.1. Remove manhole assembly from tank by removing the clamp ring bolt and clamp ring.
- 3.2.2. Remove *Normal Vent* and plug port with Betts Plug (No. 3013)
- 3.2.3. Attach manhole assembly to appropriate Betts PAF Test Fixture (No. 6685SL.)
- 3.2.4. Apply a soap solution around the perimeter of the *Cover*. See figure 3
- 3.2.5. Gradually apply pressure to the tank at the rate of approximately ½ psi/sec and observe the pressure at which bubbles first appear.
  - 3.2.5.1. The *Cover* must move 3/8" before any venting occurs. See figure 3. Do not record the pressure at which the *Cover* first moves.
  - 3.2.5.2. If the SSRV pops open forcefully, the seals in the spring cylinder and the Oil must be replaced. See section three and four for disassembly and assembly instructions.

# Betts Industries, Inc.

Warren, PA 16365

Phone: 814-723-1250

- 3.2.6. Release the pressure from the test fixture and verify the SSRV reseals.
- 3.2.7. Per 49CFR178.346-3(c) the set pressure must not be less than 3.63 psig and not more than 4.55 psig.
- 3.2.8. Replace or repair any SSRV that fails the set pressure test requirements, and retest the unit.

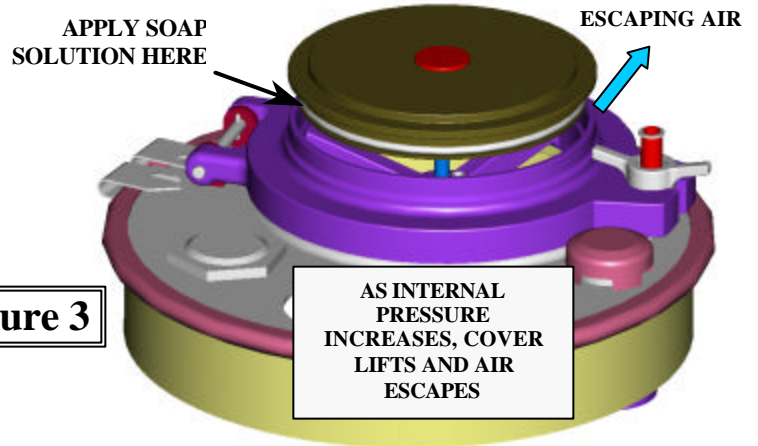

**Figure 3**

#### 4. Proper Installation of the Manhole Cover Utilizing the Clamp Ring

- 4.1. Insure the *Clamp Ring Gasket* is properly seated in the gasket channel of the collar.
- 4.2. Center the manhole cover on the gasket and fully OPEN the *Fill Cover* as shown in figure 2-A.
- 4.3. While the *SSRV Fill Cover* is open, attach the clamp ring and secure with a bolt. Tap the circumference of the clamp ring with a hammer while tightening the bolt.
- 4.4. Close the *SSRV Fill Cover* and tighten swingbolt.

#### 5. Normal Vent Test Procedure: A Normal Vent Test Tank (Part No. 6687AL) must be used to test the Normal Vents. **Note:** A regulator must be used to slowly apply pressure to the tank.

- 5.1. Pressure Test:
  - 5.1.1. 49CFR 178.346-3(b)(2) states that the normal vent for DOT 406 tanks must be set to open at not less than 1 psig.
  - 5.1.2. Screw the Normal Vent into the lid of the test tank as shown in figure 4 A.
  - 5.1.3. Slowly apply pressure to the tank and inspect the top vent opening for pressure release.
  - 5.1.4. The set pressure on a model 6496AL Normal Vent is 1.0 to 1.5 psig.
- 5.2. Vacuum Test: 178.346-3(c)(2) states that the normal vent for DOT 406 tanks must be set to open at no more than 6 ounces vacuum.
  - 5.2.1. Screw the Normal Vent into the lid of the test tank as shown in figure 4 B.
  - 5.2.2. Slowly apply pressure to the tank and inspect the top opening for pressure release. Apply a soapy solution around the vacuum disc to detect the point at which the vent opens.
  - 5.2.3. The vacuum set pressure on a model 6496AL Normal Vent is 0.25 to 0.375 psig.
- 5.3. Repair or replace any Normal Vent that does not meet the specifications.

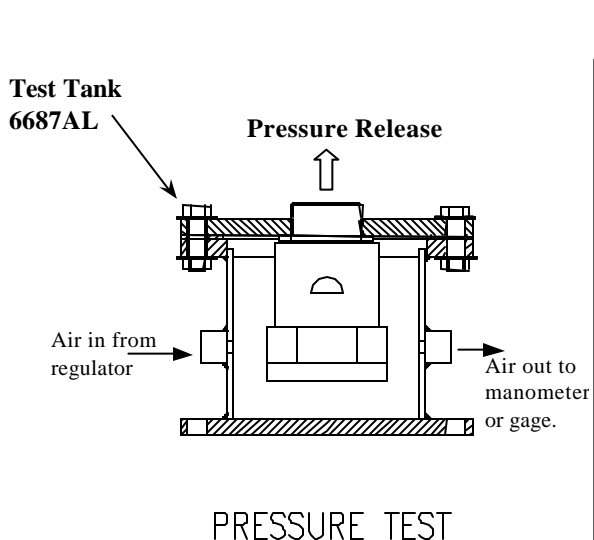

**Figure 4A**

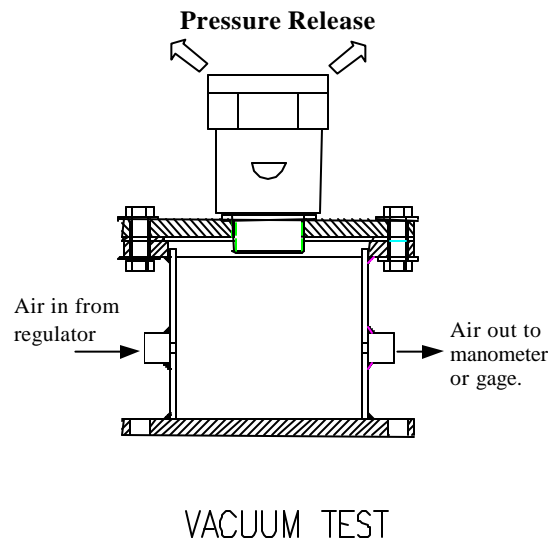

**Figure 4B**

## SECTION 3: DISASSEMBLY OF 8" SURGE SUPPRESSION RELIEF VALVE

**NOTES:**

- **UNDER NORMAL CIRCUMSTANCES, THE DISASSEMBLY OF THE SPRING CYLINDER IS NOT REQUIRED NOR RECOMMENDED, UNLESS ALL OTHER ATTEMPTS TO REPAIR THE RELIEF VALVE HAVE FAILED. IT IS RECOMMENDED THAT THE VALVE BE RETURNED TO BETTS INDUSTRIES FOR REPAIR.**
- **A SURGE SUPPRESSION DISASSEMBLY TOOL (PART # 6684MS) IS REQUIRED TO DISASSEMBLE THE SPRING CYLINDER.**

1. Relieve vapor pressure or vacuum from cargo tank.



**Failure to relieve tank pressure may result in sudden, unexpected loss of pressure. Severe personal injury or death may result.**

2. Remove the Surge Suppression Relief Valve (SSRV) from cargo tank.
  - 2.1. Removal of 10" **Fill Style** SSRV (Refer to figure 5)
    - 2.1.1. Unscrew *Wing Nut Assembly (1)* until it stops against *Stop Washer (2)*.
    - 2.1.2. The secondary safety latch requires that you must slightly lift up on *SSRV Body (3)* to rotate *Wing Nut Assembly (1)* away from body.
    - 2.1.3. Using a hammer and a 1/8" drive pin, drive out 2 *Roll Pins (4)* from *Hinge Pin (5)*.
    - 2.1.4. Remove SSRV to workbench.

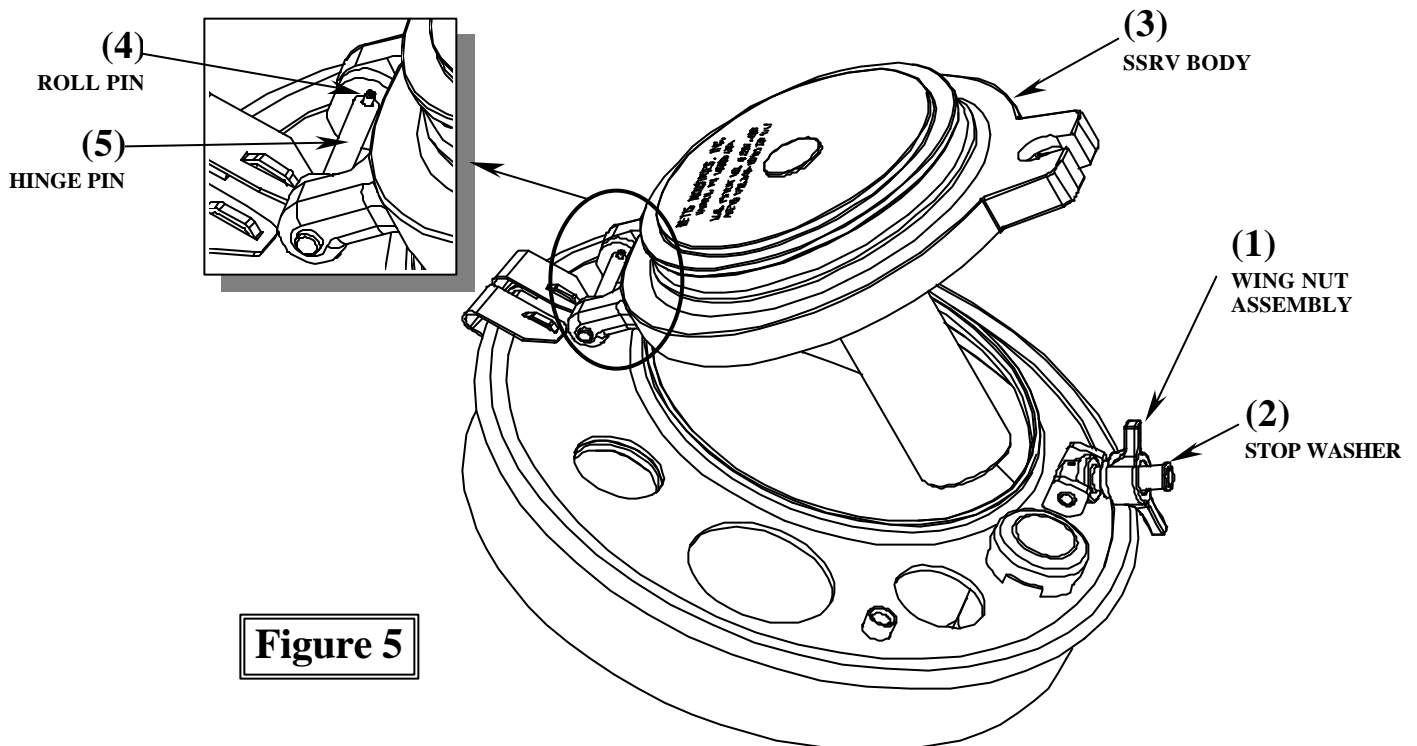

**Figure 5**

# Betts Industries, Inc.

Warren, PA 16365

Phone: 814-723-1250

3. Removal of **Bolted Style SSRV** (Refer to section 2, figure 2)
  - 3.1. Using a  $\frac{3}{4}$ " wrench, **loosen**, but **do not** remove six *hex nuts*.
  - 3.2. Lift up on SSRV until seal between SSRV and gasket is broken. Once the seal is broken, the 6 hex nuts should be removed.
  - 3.3. Remove SSRV to work bench.
4. Remove red *Plastic Plug* (6) by prying from top of *Cover* (7) as shown in figure 6.
5. Unscrew *Stem Nut* (8) using a  $\frac{7}{8}$ " socket wrench.
  - 5.1. If *Stem* (9) turns with *Stem Nut* (8), grip *Stem Jam Nut* (10) with a 1" wrench from the bottom side to prevent *Stem* from turning while unscrewing *Stem Nut*.
6. To remove *Cover* (7), gently push up from bottom side of SSRV. Push evenly to prevent the *Cover* from jamming in the SSRV bore. See figure 6 sub-view.
7. Remove *Star Washer* (11).
8. If the *Seat O-ring* (12) requires replacement, cut the o-ring with a razor blade, being careful not to damage the o-ring groove.

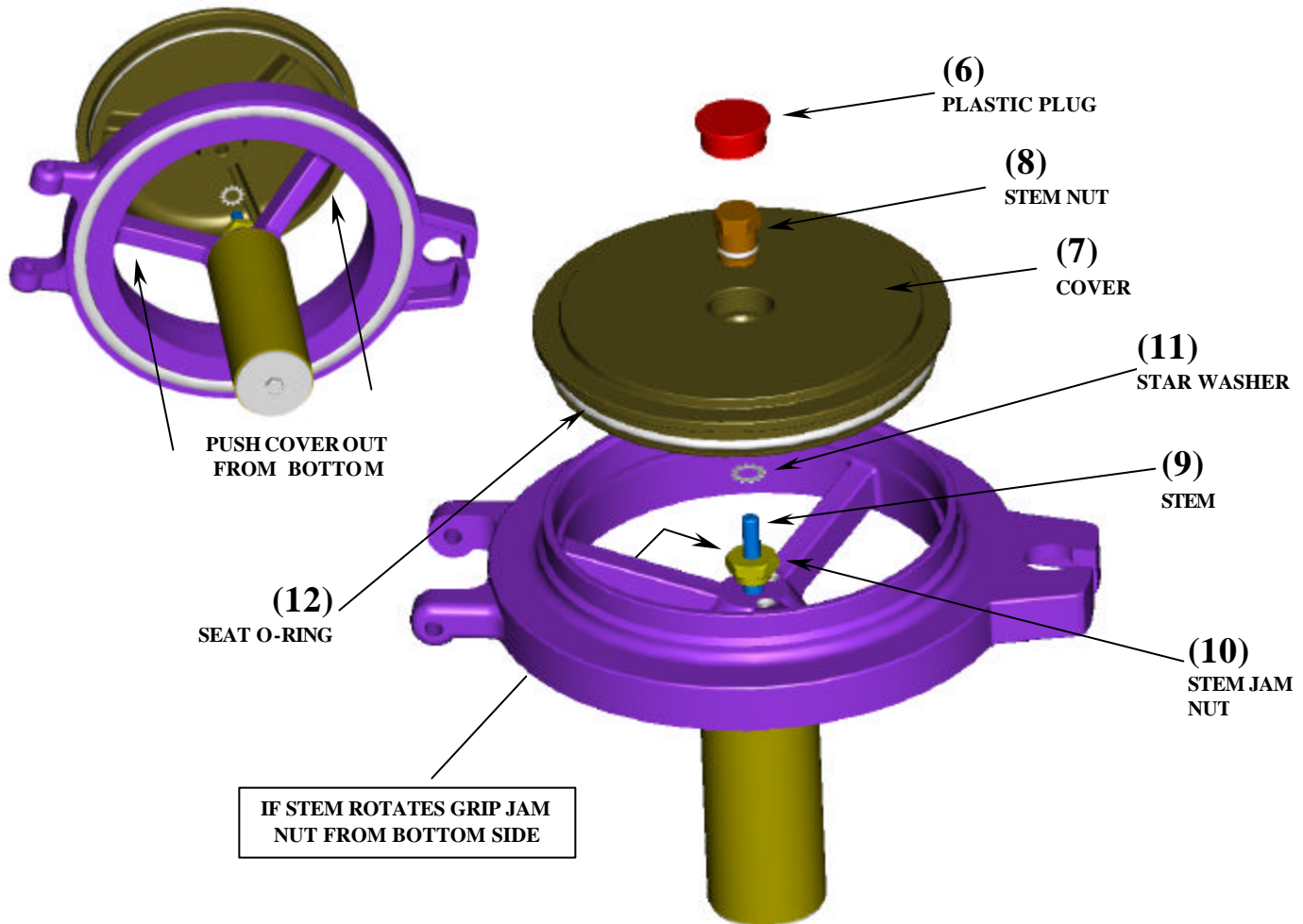

**Figure 6**

# Betts Industries, Inc.

Warren, PA 16365

Phone: 814-723-1250

## 9. Disassembly of the Spring Cylinder



The cylinder contains a compressed spring, which could cause injury if the cylinder is removed improperly. Review the following section carefully before attempting to remove cylinder.

**Note:** Under normal circumstances, the disassembly of the spring cylinder is NOT required nor recommended, unless all other attempts to repair the relief valve have failed.

### 9.1. Remove *Stem Jam Nut* (10) using a 1" wrench.

9.1.1. If *Stem* (9) starts to turn with *Jam Nut*, lock two 3/8"-16 nuts together at top of stem and use to hold *Stem*. See figure 7 Sub-view. Do **NOT** use a pair of pliers to grip stem since nicks on stem can cause o-ring seals to leak.

### 9.2. Remove the two 1/8" NPT Plugs (13) from the top of the SSRV Body (3) and drain the hydraulic oil from the *Cylinder* (14).

Note: The 1/8" NPT plugs may require hot water to loosen the teflon thread sealant.

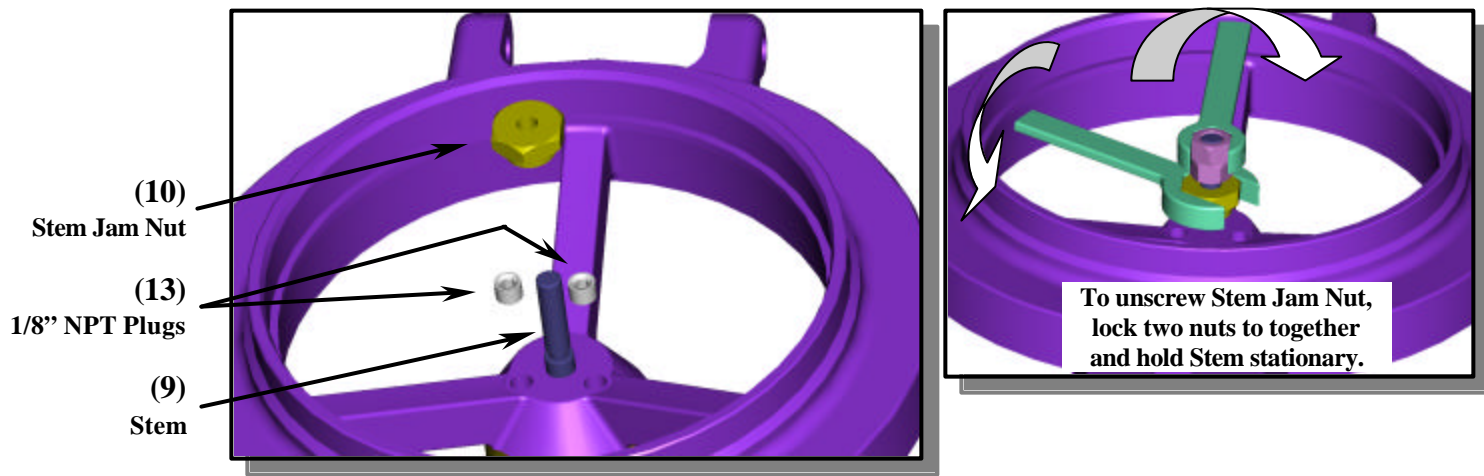

**Figure 7**

9.3. Apply petroleum jelly to the end of the tool as shown in figure 8, to reduce the chance of damaging the *Stem O-ring* (20).

9.4. Thread the Betts' *Surge Disassembly Tool* (15)(part # 6684MS) to the 3/8" male thread of the *Stem* (9) as shown in figure 8. Use a 7/32 allen wrench to tighten down the tool.

9.5. Use a 7/32 allen wrench to hold the shaft of the tool stationary with respect to the stem, while an 11/16 wrench is used to turn the *Tool Nut* (16) clockwise.

9.6. Once the *Spacer Tube* (17) has made contact with the *Body* (3), turn the nut two complete turns to compress the *Spring* (18).

9.7. The *Cylinder* (14) can now be unscrewed from the *Body* (3). Do **NOT** unscrew the stem from the tool. If slip joint pliers are required to grip the *Cylinder*, only grip within one inch from the end. Care should be taken not to damage the threads of the *Cylinder*. See figure 9.

# Betts Industries, Inc.

Warren, PA 16365

Phone: 814-723-1250



After the cylinder is removed, the spring is still under load. Do **NOT** point the spring toward yourself or a bystander.

- 9.8. To release the *Spring (18)*, hold the allen wrench stationary with respect to the *Body (3)*, and turn the *Tool Nut (16)* counter-clockwise. It is imperative that the shaft of the tool does not unscrew from the *Stem (9)* during disassembly process. Continue to back-off the *Tool Nut* until the piston is extended beyond the length of the spring. See figure 9.

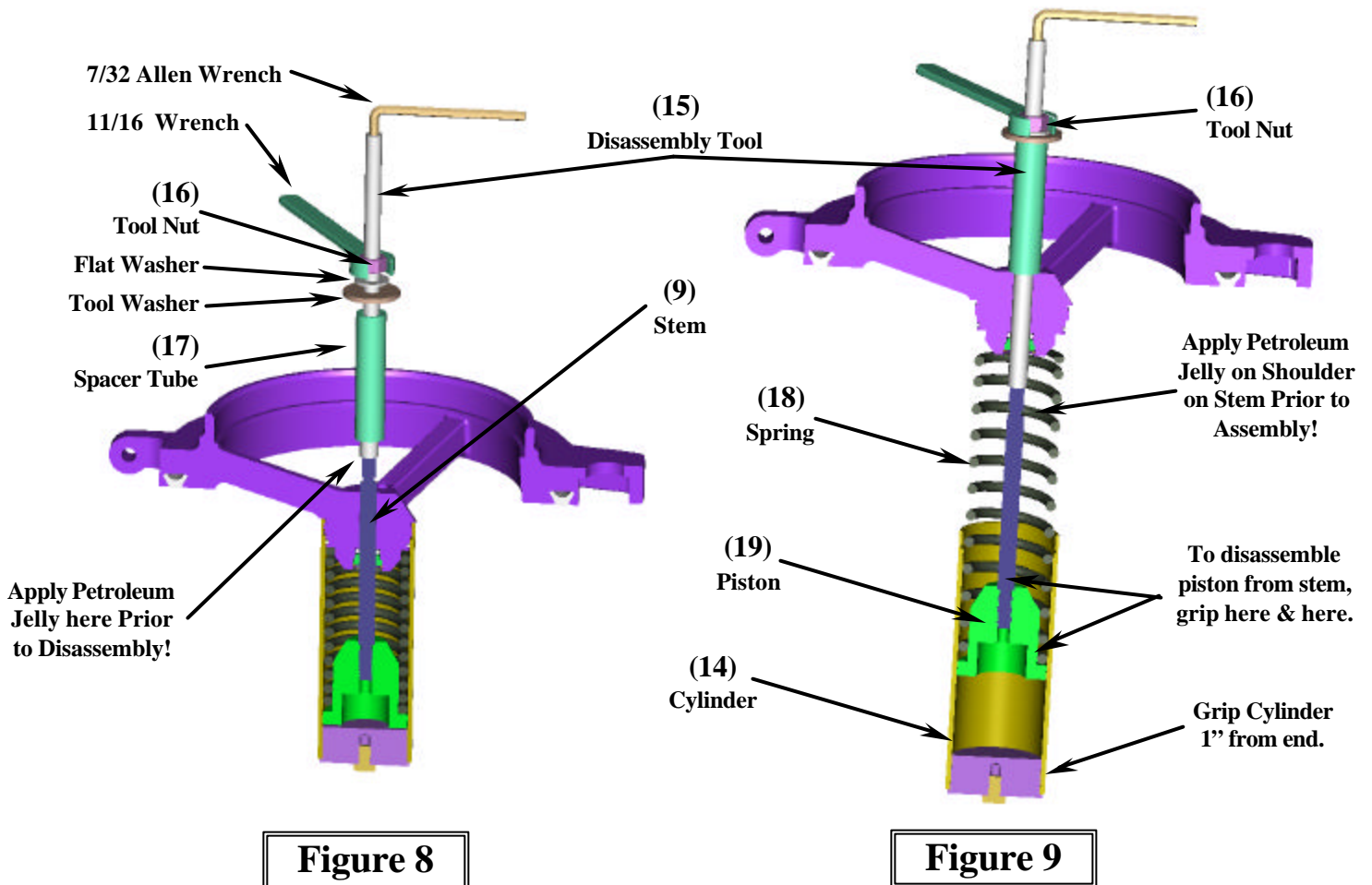

- 9.9. Insure the spring tension is released, and then unscrew the *Tool (15)* from the *Stem (9)*.

10. If needed, disassemble the stem/piston subassembly.

10.1. If the assembly uses a lock-nut on the bottom, remove lock-nut

10.2. Unscrew *Stem (9)* from *Piston (19)*. If tools are required, grip piston on small diameter only and grip stem as close to the piston as possible. See Figure 9.

## Betts Industries, Inc.

Warren, PA 16365

Phone: 814-723-1250

11. The *Stem O-ring* (20) and *O-ring Retainer* (21) are removed by using a snap ring tool to remove *Snap Ring* (22). See figure 10.
12. If the *Cylinder O-ring* (23) requires removal, cut the o-ring with a razor blade being careful not to damage the o-ring groove.
13. If the *10" Fill Gasket* (24) requires removal, cut a small slot in the center of the gasket and use a screwdriver to pry gasket out of dovetail groove, being careful not to damage groove. See figure 13.

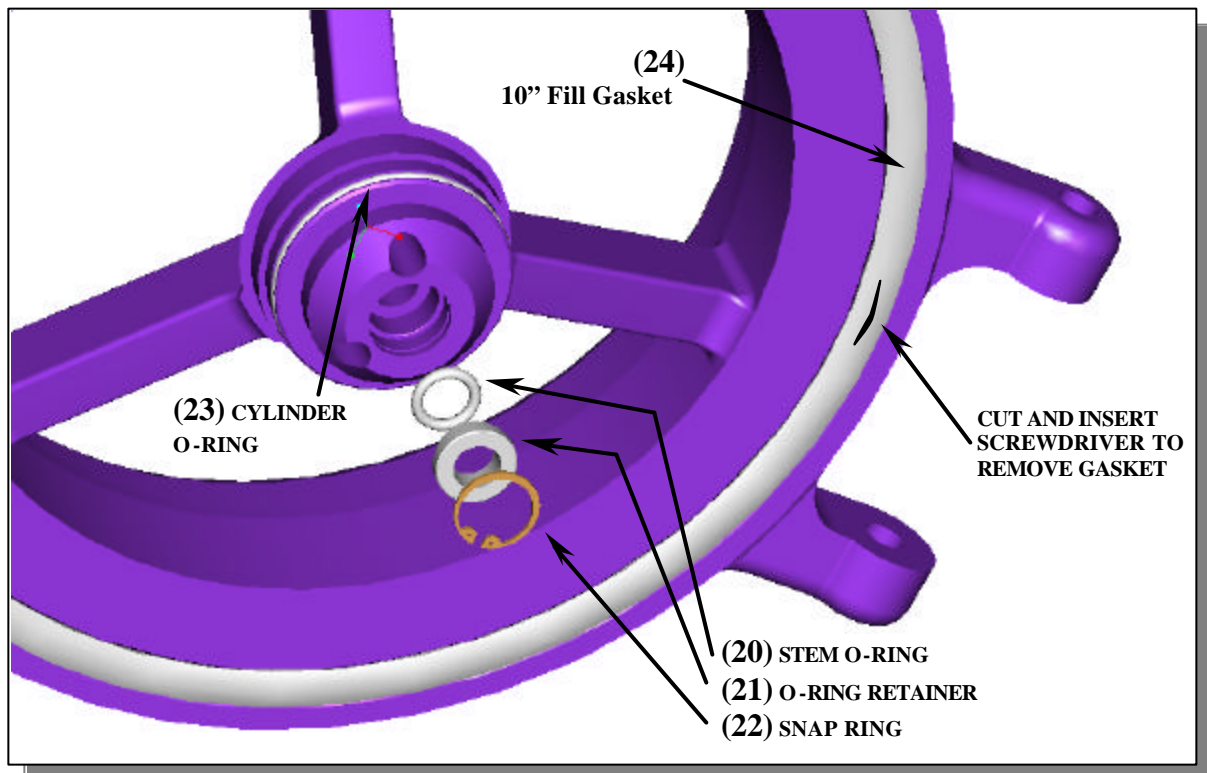
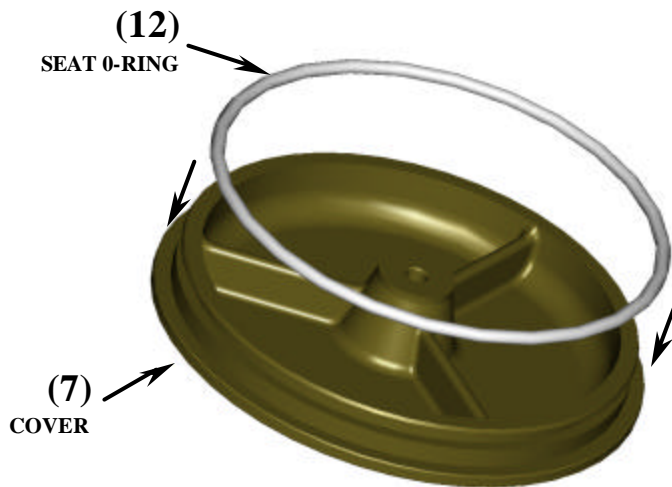

**Figure 10**

For maintenance or assembly instructions consult appropriate procedures.

## SECTION 4: ASSEMBLY OF 8" SURGE SUPPRESSION RELIEF VALVE

1. Preparation of O-Rings and Components:
  - 1.1 All parts should be cleaned and degreased to insure the removal of all product build up.
  - 1.2 All components should be inspected for damage or wear.
  - 1.3 To insure integrity of the seals, all o-rings and gaskets should be replaced using Betts' replacement parts.
  - 1.4 Inspect all o-ring grooves for damage (nicks, scratches, or burrs).
  - 1.5 All Teflon encapsulated o-rings should be pre heated with hot water and lubricated with petroleum jelly to facilitate ease of installation.
2. O-Ring Installation
  - 2.1 Snap the *Seat O-Ring (12)* into the groove in the *SSRV Cover (7)*. Figure 11
  - 2.2 Use Betts' O-Ring Tool 3830AL and slide the *Stem Nut O-Ring (25)* onto *Stem Nut (8)* as shown in figure 12.
  - 2.3 After the o-rings are in place, they must be heated with hot water once again.



**Figure 11**

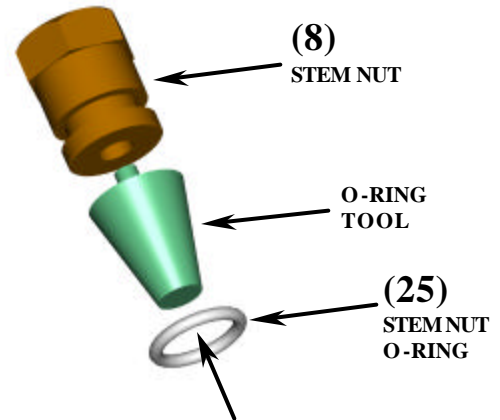

**Figure 12**

3. Body sub-assembly: Refer to figure 13.
  - 3.1 Insert *Stem O-ring (20)* into *SSRV Body (3)*.
  - 3.2 Insert *O-ring Retainer (21)* and secure by inserting the *Snap Ring (22)* into groove.
  - 3.3 Place *Cylinder O-ring (23)* into o-ring groove on *SSRV Body (3)*.
  - 3.4 Use Betts' *Dove Tail Gasket Tool (26)* (part # 6504AL) to place *10" Fill Gasket (24)* into *SSRV Body (3)*. See figure 13.
    - 3.4.1. Lubricate the gasket and dovetail groove with a soap solution.
    - 3.4.2. Using fingers, pinch the backside of the gasket together and insert a small section of the gasket into the groove.
    - 3.4.3. Use short strokes with the *DoveTail Gasket Tool (26)* to insert the gasket.
    - 3.4.4. The last portion of the gasket will need to be pushed in with fingers.

**Note: The gasket can also be installed by hand.**

# Betts Industries, Inc.

Warren, PA 16365

Phone: 814-723-1250

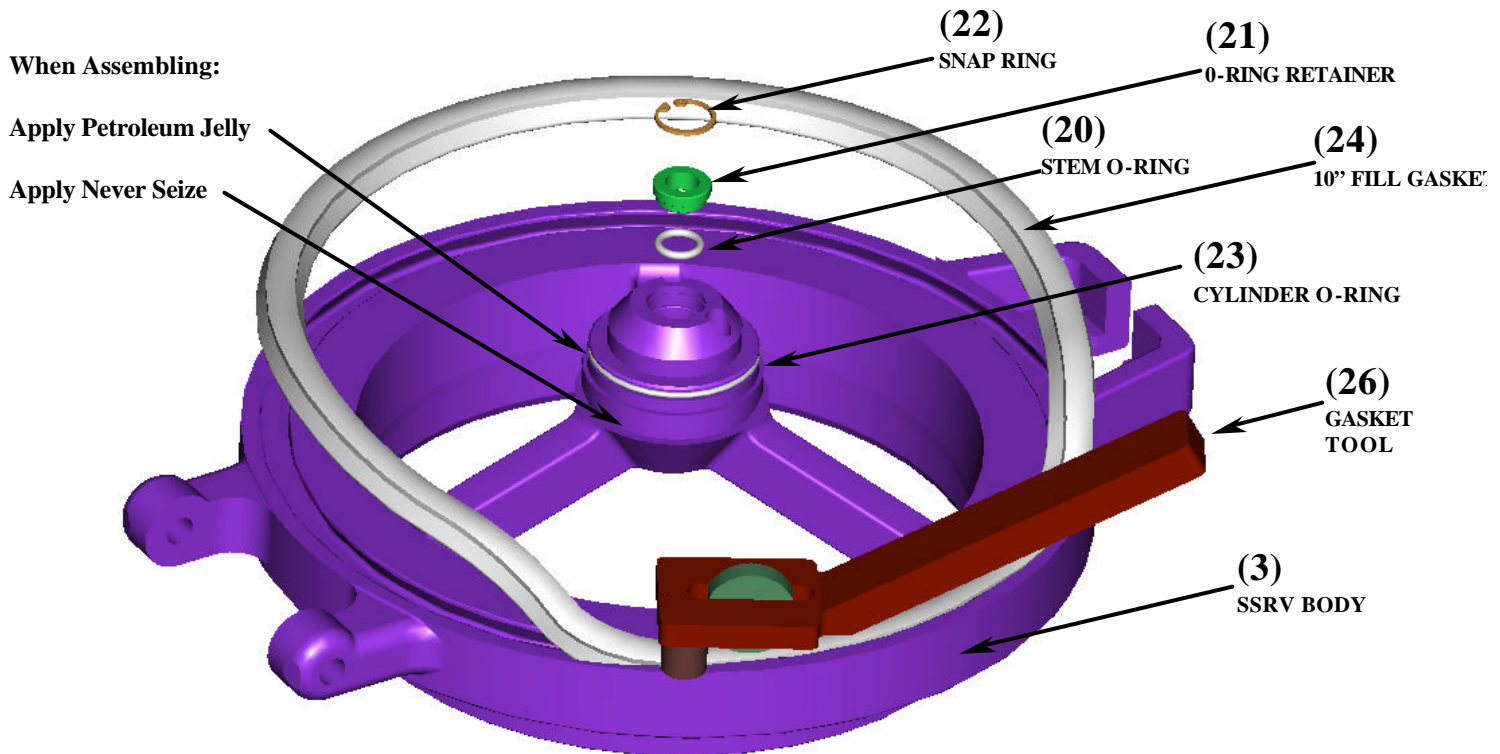

**Figure 13**

4. Piston/Stem sub-assembly: Refer to figure 14.
  - 4.1 Inspect *Stem* (9) for signs of wear or corrosion. Replace as required.
  - 4.2 Ensure the threads of the *Piston* (19) and *Stem* (9) are free from dirt and oil. Apply liquid thread-lock to the shorter threaded end of the *Stem*.
  - 4.3 Insert the shorter length of threaded *Stem* (9) into *Piston*(19) and tighten down.
    - 4.3.1. Only grip the *Stem* very close to the *Piston*, and grip the *Piston* on the small diameter. Refer to figure 14.
  - 4.4 For models with a lock-nut, follow the instructions above and complete with threading the lock-nut on the protruding threads of the *Stem*.
5. Loading the *Spring*: Refer to figure 8 and 9 of section 3.
  - 5.1 Inspect the inside of the *Cylinder* (14) for damage (dents, scratches, or corrosion). If the cylinder is damaged it must be replaced.
  - 5.2 Apply petroleum jelly to the 3/8 female thread end of the *Disassembly Tool* (15) (part # 6684MS) and gently insert it into the top center hole of the *SSRV Body* (3). Care should be taken to ease the tool past the *Stem O-Ring* (20) without damaging it.
  - 5.3 Place the spring over the piston/stem subassembly and thread the top of the *Stem* (9) into the *Disassembly Tool*. Petroleum jelly should be smeared on the shoulder of the *Stem* as shown in figure 9 of section 3.
  - 5.4 Compress the *Spring* (18) by using an 11/16 wrench to turn the *Tool Nut* (16) clockwise. (See figure 8 of section 3.)

# Betts Industries, Inc.

Warren, PA 16365

Phone: 814-723-1250



After the spring is compressed, do **NOT** point the spring toward yourself or a bystander.

- 5.5 Continue to turn the *Tool Nut (16)* until the *Spring (18)* is fully compressed or the Disassembly Tool bottoms out. Do **NOT** over tighten the Tool.
6. Installing the *Cylinder (14)*:
  - 6.1 Smear petroleum jelly around *Cylinder O-ring (23)* and smear never-seize compound on the threads of the *SSRV Body (3)* as shown in figure 10 of section 3.
  - 6.2 Carefully place *Cylinder (14)* over *Piston (19)*. Slowly screw the *Cylinder* onto the *SSRV Body (3)*. Care should be taken not to damage the threads of the *Cylinder*. Beware of cross threading. Insure the *Cylinder* is screwed completely down so there is no gap between the *Cylinder* and *Body*. See figure 8 of section 3.



The *Cylinder* must be threaded completely on the *Cover* prior to the *Disassembly Tool* being removed.

- 6.3 The *Spring (18)* can now be released by turning the *Tool Nut (16)* counter-clockwise.
- 6.4 Once the *Tool Nut (16)* has released the spring pressure, the tool can be unscrewed and removed from the *Stem (9)*.

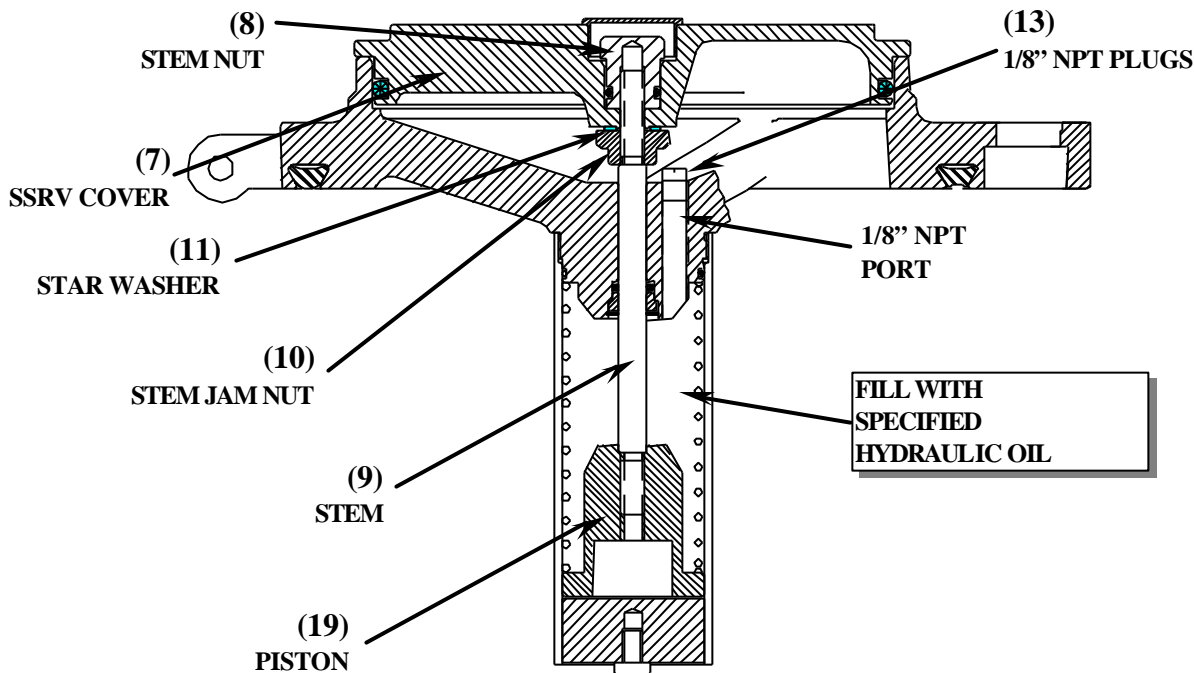

**FIGURE 14**

7. Re-filling the hydraulic oil: Refer to figure 14.
  - 7.1 **Note:** Replace the oil in the cylinder using Kendall Hyken Glacial Blue Hydraulic Fluid, or a high quality SAE 5W-10W oil with a viscosity of 90 SUS at 100°F and a pour point of no greater than -50°F.
  - 7.2 Pour hydraulic fluid through one of the 1/8" NPT openings at the top SSRV until the cylinder is completely full.

# Betts Industries, Inc.

Warren, PA 16365

Phone: 814-723-1250

- 7.3 Place thread sealant on the *NPT Plugs (13)* and insert both into the SSRV.
8. Installation of the SSRV Cover (7)
  - 8.1 Place removable thread-lock on the threads of the *Stem (9)* and screw the *Stem Jam Nut (10)* all the way until it bottoms out. The round end of the *Jam Nut* faces down. See figure 7 of section 3.
  - 8.2 Next, place the *Star Washer (11)* on the *Stem* and gently slide the *SSRV Cover (7)* into place over the *Stem*. See figure 6 of section 3.
  - 8.3 Screw the *Stem Nut (8)* onto the *Stem* ensuring that the o-ring is in place on the *Stem Nut*. Push the *Plastic Cap (6)* into the top of the *Cover*.
9. Installation of 10" Fill Style SSRV to Cargo Tank (Refer to figure 5 section 3)
  - 9.1 Line up hinge holes on SSRV to holes on lugs and insert *Hinge Pin (5)* through hole s.
  - 9.2 Using hammer, drive the two *Roll Pins (4)* into *Hinge Pin (5)*
  - 9.3 Tighten down *Wing Nut Assembly (1)*.
10. Installation of Bolted Style SSRV to Cargo Tank (Refer to figure 2 section 2)
  - 10.1 Place Mounting Gasket over studs.
  - 10.2 Place SSRV over studs.
  - 10.3 Place six lock washers and nuts on studs and follow standard flange bolt tightening procedures.