

Engineering Bulletin 4-2002

Date: October 23, 2002

Subject: Emergency Valve Straight Lift Mechanism – Operational Notes

A variety of Betts Emergency Valves are equipped with a “Straight Lift Mechanism” in place of the more traditional cam and stem style lift mechanism. The straight lift mechanism is an improvement over the cam and stem designs because it produces less cocking of the valve piston assembly when the valve is actuated. This reduces wear in the valve and improves the over-all valve operation.

The basic components of straight lift mechanism are the cam shaft, the lift arm, the lift stem, the lift stem spring and a tapered lift socket in the bottom of the valve o-ring holder that engages the lift stem. To open the valve, the camshaft is rotated approximately 90° by either an air cylinder or a cable operator. The straight lift arm is attached to the camshaft and rotates upward toward the bottom of the valve piston. This motion causes the lift stem to contact the bottom of the o-ring holder inside the tapered lift socket and to lift the valve to the open position. Figures 1 and 2 illustrate the position of the straight lift components with the valve in the closed and open positions.

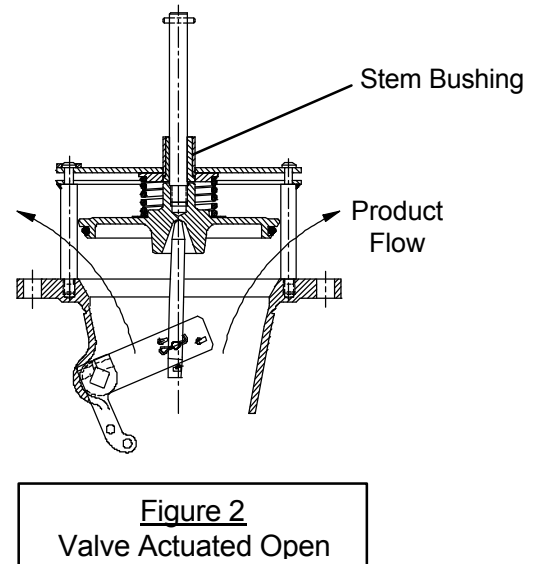
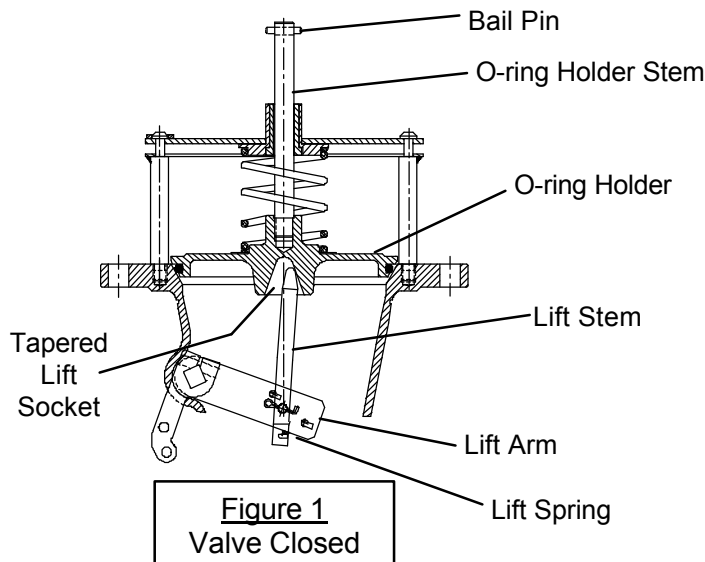
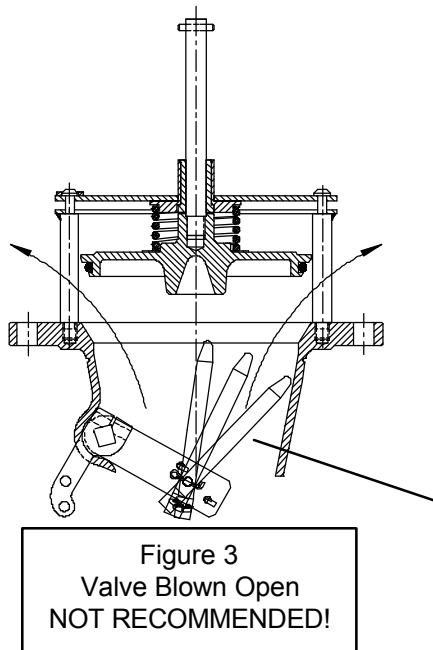

Figure 1 shows the valve in the closed position. Note that the lift stem is trapped inside the lift socket and cannot fall out of the socket, even if the lift spring is missing. The lift spring holds the lift stem in the upright position to insure the lift stem engages the lift socket properly at assembly.

Figure 2 shows the valve in the open position. Note that the o-ring holder is pushed up just short of the stem bushing. As long as the cable tension (cable operated valve) or air pressure (air operated valve) is maintained to hold the valve open, the lift arm will remain in the position shown. Also note that pressure from the product acting against the bottom of the o-ring holder cannot push the o-ring holder higher. So, if the valve is properly actuated open, the lift stem cannot disengage from the tapered lift socket.

Betts Industries, Inc.

1800 Pennsylvania Ave. West
Warren, PA 16365 U.S.A.



Product Flow
Pressure from
loading rack
pump pushes
valve open.

Turbulence from
product flow may
cause lift stem to
move back and
forth between the
positions shown

Figure 3 shows the valve with the o-ring holder pushed open by the pressure of the loading rack pump. The pressure generated by a product pump will easily push the valve open, even if the valve is not actuated to the open position by either the cable operator or the air cylinder. If this happens, the lift stem will be disengaged from the lift socket and will oscillate through the range of positions shown due to the turbulence of the product moving through the valve. When the pump stops, the o-ring holder will move to the closed position, but if the lift stem is still moving, it may not engage the lift socket

As shown in the figures, the lift stem cannot become disengaged from the lift socket unless the valve is forced open by the product pump. There are two scenarios that could result in this occurring.

1. Valve Blown Open

If the product pump is used to blow open the valve without first actuating the valve to the full open position, the lift stem will disengage from the lift socket as shown in figure 3. **This practice is not recommended!**

2. Bleed Off of Air Pressure to Valve Air Cylinder During Loading Process

If the valve is air operated, the air pressure to the air cylinder must be maintained throughout the entire loading process. If an air leak allows the cylinder pressure to drop while the product pump is running, the lift stem will drop out of the lift socket as shown in figure 3. **Air system or air cylinder leaks must be repaired to prevent this.**

REPAIR PROCEDURE

If the lift stem becomes disengaged from the lift socket, use the following procedure to get it reengaged properly.

1. Disengage air cylinder or cable from valve lever arm. Rotate lever arm clockwise until it stops, then rotate counterclockwise until it stops again. Maintain lever in this position and reattach air cylinder or cable and test operation of valve. This method will not work on all valves with straight lift mechanisms and it will only work if the lift spring is operational.
2. If step 1 does not work, the next easiest solution is to pull the valve open from the top of the tank. This will require a long rod with a hook fashioned to grasp the bail pin in the top of the o-ring holder stem. With the air cylinder/cable operator in the closed position, pull the o-ring holder stem up to allow the lift stem to be repositioned and then lower the stem. Test valve to insure proper engagement. This method will only work if the lift spring is operational.
3. If steps 1 and 2 do not work, the valve bonnet plate must be manually removed from the valve along with the o-ring holder. Reassemble making sure the lift stem is engaged properly inside the lift socket as shown in figure 1. Test valve to insure proper engagement.