



# INSTALLATION, OPERATION, & MAINTENANCE MANUAL

MAINTENANCE MANUAL #: MM-SV001

6-23-09

Rev. A

Page 1 of 8

## PNEUMATIC SLIDING VALVE

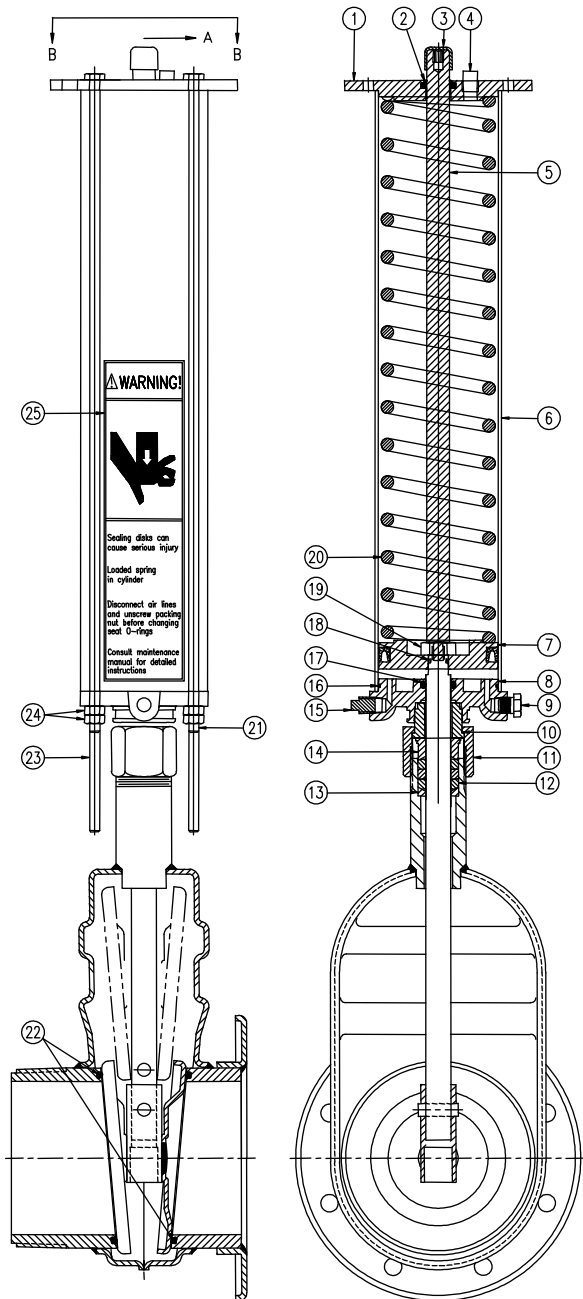
### PART NUMBERS (Including, but not inclusive)

SV704MSTS, SV714MSTS, SV754MSTS, SV764MSTS, SV774MSTS, SV706MSTS,  
SV716MSTS, SV756MSTS, SV766MSTS, SV776MSTS, SV724MSTS, SV726MSTS,  
SV744MSTS, SV746MSTS, SV734MSTS, SV736MSTS

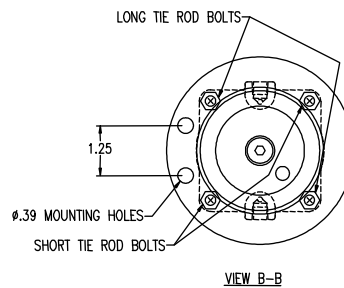


**Table of Contents**

1.0	General	Page 3
2.0	Description & Intended Use	Page 4
3.0	Installation	Page 4
4.0	Inspection & Testing	Page 4
5.0	Disassembly & Rebuild	Page 5
6.0	Troubleshooting Guide	Page 8



NO.	DESCRIPTION	REQ.	MATERIAL	PART NO.
1	END PLATE	1	E-COAT ALUMINUM	75200ALEY
2	WIPER	1	POLYURETHANE	8N4700
3	PROTECTIVE CAP	1	VINYL	9Z6180
4	VENT PLUG	1	SINTERED BRONZE	9Z4895
5	INDICATOR ROD	1	ALUMINUM	75249AL
6	CYLINDER	1	FIBERGLASS	75202FG
7	PISTON & PISTON SEAL	1	ALUMINUM W/ BUNA-N	17660ALBN
8	END PLATE	1	ALUMINUM	75191AL
9	FUSIBLE PLUG	1	BRASS	FP15003BR
10	SWIVEL NUT	1	303 STAINLESS	75193SL
11	PACKING NUT	1	303 STAINLESS	75192SL
12	PACKING SET OF 3 PCS	1	NON-ASBES./TEFLON	15227NT
13	BOTTOM GLAND	1	316 STAINLESS	C15076SS
14	TOP GLAND	1	316 STAINLESS	C15220SS
15	NPT PLUG	1	PLASTIC	9Z6148
16	END PLATE O-RING	1	BUNA-N	17666BN
17	SHAFT SEAL O-RING	1	BUNA-N	18066BN
18	SHAFT SEAL O-RING	1	BUNA-N	17781BN
19	HALF NUT	1	ZINC PLATED	9Q5910
20	MAIN SPRING	1	E-COAT CHROME SILICONE	75197EY
21	SHORT TIE ROD BOLTS	2	304 STAINLESS	75230SL
22	SEAT O-RING 4" VALVE	2	TEF. ENCAP. SILICONE	19430TS
	SEAT O-RING 6" VALVE			19428TS
23	LONG TIE ROD BOLTS	2	304 STAINLESS	75231SL
24	1/4-20 HEX NUT	8	BRASS	9Q5038
25	WARNING LABEL	1	VINYL	9Z4020






**Figure 1**

## 1.0 General

- 1.1 It is strongly recommended that this entire manual be read prior to any operation, disassembly, or assembly of this equipment.
- 1.2 Betts Industries, Inc. provides this manual as a guideline for reference only and assumes no responsibility for personal or property damage that may occur in conjunction with this manual. Betts Industries, Inc. cannot be held responsible for incorrect installation, operation or maintenance of product.
- 1.3 Betts Industries, Inc. recommends all equipment be placed on a regular maintenance schedule that includes the routine replacement of seals and gaskets and visual inspection for leaks and corrosion. The end user must make their own determination and set their own schedule based upon use and environment. In some cases, regulations may dictate the minimum testing frequency of items. Make sure operators are aware of all applicable codes.
- 1.4 Only trained personnel should attempt to perform maintenance on this equipment.
- 1.5 As with any maintenance work, proper safety gear and procedures must be used at all times. A list of hazards may include but are not limited to contents under pressure, loaded springs, residual product, flammable liquid and vapors, pinch points.
- 1.6 Safety alert symbols are used to alert operator to potential personal injury hazards. These symbols are per ANSI 2535.5 and are listed below. Operator **MUST** obey all instructions that follow a safety symbol.

Alerts will be used to indicate known safety concerns. Additional concerns are possible and should be identified and avoided by the operator.

	Indicates an imminently hazardous situation which, if not avoided, <b>will result</b> in death or serious injury.
	Indicates a potentially hazardous situation which, if not avoided, <b>could result</b> in death or serious injury.
	Indicates a potentially hazardous situation which, if not avoided, <b>may result</b> in minor or moderate injury. It may also be used to alert against unsafe practices.

- 1.7 Product Warranty shall be void if product is subject to misapplication, misuse, neglect, alteration or damage.
- 1.8 Specific design details described in this document are for reference only and are subject to change without notice. See Betts Industries, Inc. web page for the most recent revision to this document. [www.bettsind.com](http://www.bettsind.com)
- 1.9 For additional questions or more detailed technical assistance, contact the Betts Industries, Inc. Sales or Engineering Department at (814)723-1250.

## **2.0 Description and Intended Use**

- 2.1 The Betts Pneumatic Sliding Valves is a self closing external stop valve. It features an air cylinder actuator in conjunction with replaceable Teflon® encapsulated o-ring seats. Air pressure is used to open the valve and spring pressure closes the valve.
- 2.2 A fusible plug is installed in the air cylinder to dump air pressure in case of fire.
- 2.3 A complete information page can be found in the catalog section 17 page 4C & 4D.

## **3.0 Installation**

- 3.1 Flange to flange connections may require a gasket to seal between the valve flange and connecting flange of the equipment. See section 40 of the catalog for gasket details.
- 3.2 When bolting the flanges, care should be taken to be sure to not over compress gasket material. Initial tightening should be done with a star pattern followed by clockwise pattern to ensure even pressure on gasket. It may be necessary to retighten the nuts after a 24 hour period.
- 3.3 The air cylinder must be properly supported by bolting the air cylinder endplate (1) to a rigid bracket directly connected to the same support member as the valve to prevent fatigue in the air cylinder neck or rotation of the air cylinder
- 3.4 When mounting valve, be sure there is sufficient clearance to allow the indicator rod (5) to project beyond the air cylinder endplate (1) and clearance for the air cylinder to be slid outward to change the valve seat o-rings (22). See catalog section 17, page 4C for how much clearance is needed. See section 5.1 for instructions to change valve seat o-rings (22).

## **4.0 Inspection and Testing**


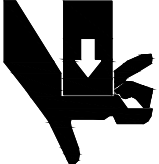
- 4.1 Visual Inspection:
  - 4.1.1 At least 1 time per year, the valve should be visually inspected for cracks, corrosion, defects in welds and defects in seals and seal areas.
  - 4.1.2 At least 1 time per year, the valve main seat and air cylinder should be inspected and tested to ensure proper operation.
  - 4.1.3 Be sure to consult the current copy of the Code of Federal Regulations to ensure the most up to date testing/inspection requirements are being met.
- 4.2 Inspect/test air cylinder:
  - 4.2.1 Attach air line to input on bottom plate (8) and charge actuator with 90 psi.
  - 4.2.2 Valve should open fully. Hold pressure for 2 minutes.
  - 4.2.3 Check for valve closing due to air leaks.
  - 4.2.4 Inspect bottom cylinder endplate (8) for leakage.
  - 4.2.5 If leakage is detected, see trouble shooting guide in section 6.

#### 4.3 Test Main Seat to ensure proper seal

- 4.3.1 With valve in the closed position, apply 50 psi or the tanks MAWP to the valve and inspect for leaks. This pressure should be applied for at least 30 seconds.


### 5.0 Disassembly and Rebuild Instructions

#### 5.1 To change seat o-rings:

 <b>WARNING</b>	DO NOT ATTEMPT TO CHANGE SEAT O-RINGS (20) WITHOUT DETACHING AIR SOURCE FROM AIR CYLINDER AND AIR CYLINDER FROM VALVE BODY. SEALING DISCS CAN CAUSE SERIOUS INJURY.	
--	---	---

- 5.1.1 Disconnect air line from air cylinder and unscrew packing nut (11).
- 5.1.2 Open valve by pulling air cylinder away from valve exposing the removable o-rings (22). It may be necessary to use a small rubber hammer to tap on lower air cylinder endplate (8) to free the discs.
- 5.1.3 Carefully remove old seat o-rings (22). DO NOT scratch or damage seat/groove where the seat o-rings (22) are installed.
- 5.1.4 Apply silicone lubrication to seat o-rings (22) and Install. Heating the o-rings in hot tap water for a short time may ease installation. Be sure seat o-rings (22) are fully installed into o-ring grooves.
- 5.1.5 Reinstall air cylinder, closing the valve. It may be necessary to use a small rubber hammer to tap the upper air cylinder endplate (1) to seat the discs.
- 5.1.6 Tighten packing nut (11) to 25 ft-lbs. and check operation of valve. If the valve shaft sticks or does not operate correctly, loosen packing nut slightly.

#### 5.2 To disassemble or replace air cylinder.

 <b>CAUTION</b>	AIR CYLINDER CONTAINS A LOADED SPRING. DO NOT ATTEMPT TO DISASSEMBLE AIR CYLINDER IF TIE ROD BOLTS (21) & (23) HAVE BEEN DAMAGED OR MODIFIED. TWO (2) OF THE TIE ROD BOLTS SHOULD PROJECT 3" BEYOND THE END PLATE (8).
--	--

- 5.2.1 If needed Part #47191ALBN is a complete replacement air cylinder kit. All parts are loose & the air cylinder must be assembled onto the valve.
- 5.2.2 Disconnect air line.
- 5.2.3 Remove protective cap (3) but leave indicator rod (5) in place.
- 5.2.4 Removed 2 short tie rod bolts (21) and only the outer nuts (24) from long tie rod bolts (23).
- 5.2.5 Loosen remaining nut (24) on one of the long tire rods (23) 2 full turns, then loosen the remaining nut (24) on the other long tire rod (23) 2 full turns. Repeat this procedure until the main spring (20) is fully unloaded.
- 5.2.6 Remove top end plate (1), main spring (20), and cylinder (6) and set aside.

- 5.2.7 Insert allen wrench into top of indicator rod (5) and unscrew rod from stem and set aside.
- 5.2.8 Remove half nut (19) and piston (7).
- 5.2.9 Unscrew packing nut (11) from valve body.
- NOTE: The swivel nut (10) is connected to the bottom end plate (8) with non-removable thread locking compound – Do not separate.
- 5.2.10 Inspect the piston seal (17669BN), end plate o-ring (16), shaft o-ring (17), shaft-nut o-ring (18) and replace if necessary.
- NOTE: Kit #75429BN is available for rebuild and it contains item numbers 2, 12, 16, 17, 21, 23, 24 and 17669BN (piston u-cup seal).
- 5.2.11 Apply silicone grease to all o-rings, u-seal and install them in the appropriate locations.
- 5.2.12 Assemble packing nut (11), swivel nut (10) and bottom end plate (8) sub assembly to valve body.
- 5.2.13 Install half nut (19) and piston (7) with u-cup seal.
- 5.2.14 Assemble indicator rod (5) to stem and tighten using allen wrench.
- 5.2.15 Assemble cylinder (6) by slightly twisting the cylinder (6) over the end plate o-ring (16). Care should be taken to not pinch the end plate o-ring (16).
- 5.2.16 Slide upper end plate (1) over the indicator rod (5) and into the cylinder (6).
- 5.2.17 Be sure to place the long tire rod bolts (23) in the diagonally opposite corners of the air cylinder end plates (1) and (8).
- 5.2.18 Tighten one nut (24) on one of the long tie rods (23) 2 turns, then tighten the nut on the other long tie rod 2 turns. Repeat this procedure until the main spring is fully loaded. Be sure that the upper end plate (1) is correctly positioned inside the cylinder (6).
- 5.2.19 Install the short tie rods (21) and remaining nuts (24) with double nuts on each tie rod (21)(24). Be sure the double nuts are locked together to keep from loosening.
- 5.2.20 Install protective cap (3) on indicator rod (5).
- 5.3 To adjust stem packing.
- 5.3.1 Tighten packing nut (11) to 25 ft-lbs and check operation of valve.
- 5.3.2 If valve sticks or does not operate, loosen packing nut (11) slightly and check operation again.
- 5.3.3 Replace packing (12) if necessary.
- 5.4 To manually open valve.



THIS TECHNIQUE IS TO BE USED IN AN EMERGENCY ONLY.  
DO NOT USE THIS TECHNIQUE TO SERVICE THE VALVE.

- 5.4.1 Disconnect air line.

- 5.4.2 Remove protective cap (3) and using hex groove, unscrew indicator rod (5) and slide out of assembly.
- 5.4.3 Thread 5/16-18 all-thread at least 15" long into valve stem in place of the indicator rod (5).
- 5.4.4 Install a flat washer over the all-thread and up against the top endplate (1) and screw a nut onto the all-thread rod.
- 5.4.5 Tighten nut until valve is open.



**⚠ WARNING**

VALVE WILL CLOSE UNDER SPRING PRESSURE WHICH COULD INJURE ANY PART OF THE BODY LEFT IN THE VALVE OPENING. BE SURE EVERYTHING IS CLEAR FROM THE VALVE OPENING BEFORE CLOSING THE VALVE.

- 5.4.6 To close valve, hold the all-thread so it cannot turn and loosen nut slowly. If the all-thread is not held from turning, it will unscrew from the stem and the valve will slam shut creating a dangerous situation.
- 5.4.7 Once the spring pressure has closed the valve, the all thread can be removed from the assembly and the indicator rod (5) can be replaced.

SEE TROUBLE SHOOTING GUIDE ON PAGE 8

## 6.0 Troubleshooting Guide

Problem	Cause	Solution
 <b>WARNING</b>	Damaged or missing seat o-rings (22)	Replace seat o-rings (22). See section 5.1.
	Scratched or damaged discs	If discs are damaged, valve needs to be replaced.
	<p>DETACH AIR SOURCE FROM AIR CYLINDER AND CYLINDER FROM VALVE BODY. SEALING DISCS CAN CAUSE SERIOUS INJURY</p> 	
	Seat area obstructed with debris in area below discs	Clear seat area and inspect o-rings (22). If o-rings (22) need replaced, see section 5.1
Valve will not open	Damaged or worn end plate o-ring (16).	Replace end plate o-ring (16), see section 5.2.
	Damaged or worn shaft seal o-ring (17) & (18).	Replace shaft seal o-ring (17) & (18), see section 5.2.
	Damaged or worn u-cup seal on piston (7)	Replace u-cup seal (17669BN), see section 5.2.
	Damaged or cracked cylinder (6)	Replace cylinder (6), see section 5.2.
	Packing nut (11) too tight	Loosen packing nut (11) and tighten to 25 ft-lbs.
	Damaged or worn packing (12)	Change/adjust packing (12). See section 5.3
Product leaking through packing (12)	Packing nut (11) needs adjusted	See section 5.3 for packing nut (11) adjustment.
	Damaged or worn shaft.	Replace valve.