



INSTALLATION, OPERATION, & MAINTENANCE MANUAL

MAINTENANCE MANUAL #: MM-HP001

4-20-09

Rev. A

Page 1 of 12

HYDRAULIC PUMP

PART NUMBER

HP46982ALSL & HP46982SL

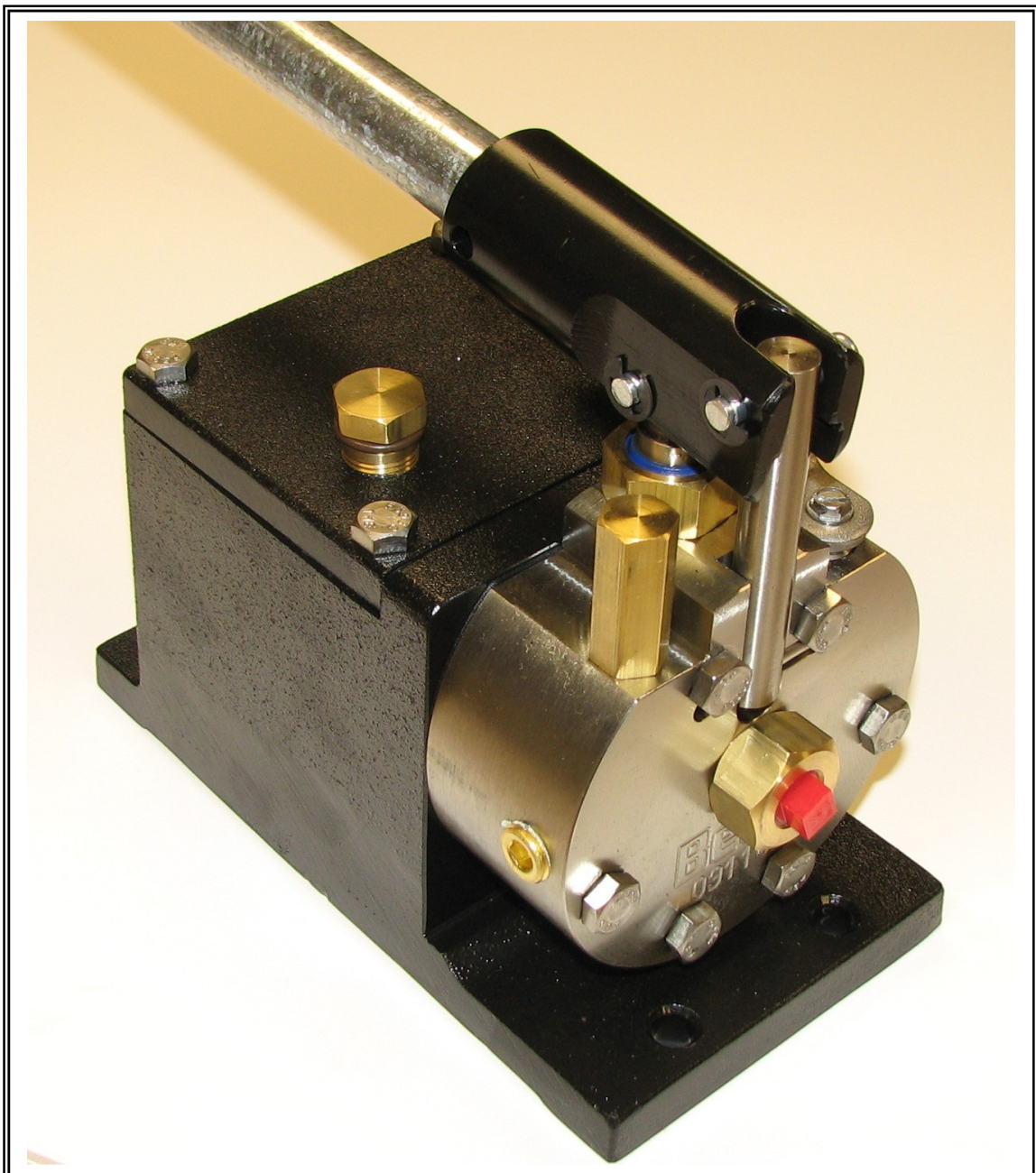

Table of Contents

1.0	General	Page 3
2.0	Description & Intended Use	Page 4
3.0	Installation	Page 4
4.0	Inspection & Testing	Page 4
5.0	Disassembly & Rebuild	Page 4
6.0	Troubleshooting Guide	Page 5

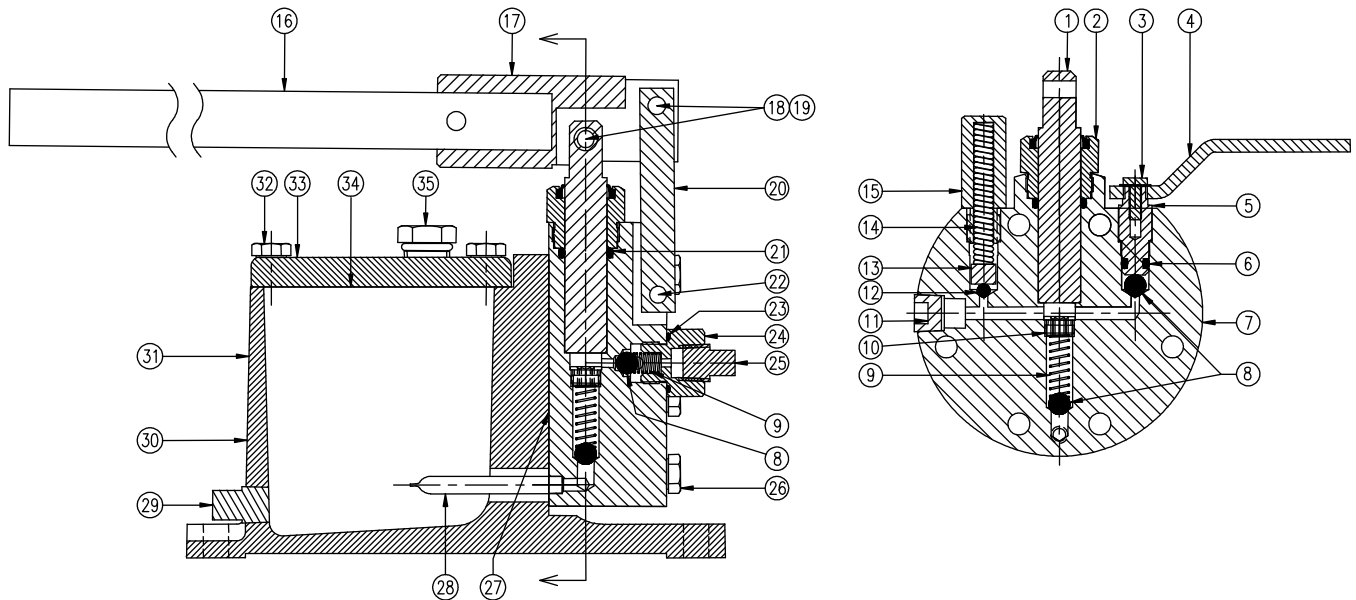





Figure 1

No.	Description	Req.	Material	Part No.	No.	Description	Req.	Material	Part No.
1	Piston	1	303 Stainless	75233SL	19	E-Clip	2	Coated Steel	9Q4733A
2	Bushing/Wiper	1	Brass/Polyurethane	75239BR	20	Link	1	303 Stainless	75234SL
3	Release Handle Screw	1	304 Stainless	9Q4170	21	Piston Seal	1	Buna-N	17946BN
4	Pressure Release Handle	1	304 Stainless	75145SL	22	Pin	1	303 Stainless	9Q4950
5	Release Stem	1	304 Stainless	75236SL	23	Outlet O-ring	1	Buna-N	75584BN
6	Release Stem Seal	1	Buna-N	75254BN	24	Outlet	1	Brass	75583BR
7	Valve Block	1	303 Stainless	35965SL	25	1/4" NPT Pipe Plug	1	Plastic	9Z6145
8	Ø.313 Ball	3	440 Stainless	9Z8505	26	Valve Block Cap Screw	6	304 Stainless	9Q5975
9	Ball Spring	2	302 Stainless	75255SL	27	Head Gasket	1	Cellulose Fiber	75244CF
10	Spring Retainer	1	Brass	75298BR	28	Filter Screen	1	304 Stainless	75148SL
11	Auxiliary Outlet Plug	1	Brass	9V4925	29	Drain Plug	1	Brass	9V4914
12	Ø.188 Ball	1	440 Stainless	9Z8507	30	Reservoir	1	Aluminum E-Coat	46973ALEY
13	Bypass Plug	1	304 Stainless	75237SL	31	Priming Instructions	1	Vinyl	9Z4022
14	Bypass Spring	1	17-7PH Stainless	75256SL	32	Cover Cap Screw	4	304 Stainless	9Q5861
15	Bypass Cap	1	Brass	75238BR	33	Cover Plate	1	Aluminum E-Coat	75246ALEY
16	Handle	1	Galv. Steel	HP19165-01	34	Cover Gasket	1	Cellulose Fiber	75245CF
17	Beam	1	E-Coat Steel	75240EY	35	Vent Plug	1	Brass/Viton	75242BR
18	Clevis Pin	2	Zinc Plated Steel	9Q4733					

1.0 General

- 1.1 It is strongly recommended that this entire manual be read prior to any operation, disassembly, or assembly of this equipment.
- 1.2 Betts Industries, Inc. provides this manual as a guideline for reference only and assumes no responsibility for personal or property damage that may occur in conjunction with this manual. Betts Industries, Inc. cannot be held responsible for incorrect installation, operation or maintenance of product.
- 1.3 Betts Industries, Inc. recommends all equipment be placed on a regular maintenance schedule that includes the routine replacement of seals and gaskets and visual inspection for leaks and corrosion. The end user must make their own determination and set their own schedule based upon use and environment. In some cases, regulations may dictate the minimum testing frequency of items. Make sure operators are aware of all applicable codes.
- 1.4 Only trained personnel should attempt to perform maintenance on this equipment.
- 1.5 As with any maintenance work, proper safety gear and procedures must be used at all times. A list of hazards may include but are not limited to contents under pressure, loaded springs, residual product, flammable liquid and vapors, pinch points.
- 1.6 Safety alert symbols are used to alert operator to potential personal injury hazards. These symbols are per ANSI 2535.5 and are listed below. Operator **MUST** obey all instructions that follow a safety symbol.

Alerts will be used to indicate known safety concerns. Additional concerns are possible and should be identified and avoided by the operator.

	Indicates an imminently hazardous situation which, if not avoided, will result in death or serious injury.
	Indicates a potentially hazardous situation which, if not avoided, could result in death or serious injury.
	Indicates a potentially hazardous situation which, if not avoided, may result in minor or moderate injury. It may also be used to alert against unsafe practices.

- 1.7 Product Warranty shall be void if product is subject to misapplication, misuse, neglect, alteration or damage.
- 1.8 Specific design details described in this document are for reference only and are subject to change without notice. See Betts Industries, Inc. web page for the most recent revision to this document. www.bettsind.com
- 1.9 For additional questions or more detailed technical assistance, contact the Betts Industries, Inc. Sales or Engineering Department at (814)723-1250.

2.0 Description and Intended Use

- 2.1 The Betts Hydraulic Pump HP46982ALSL is designed as a corrosion resistant, reliable hydraulic pump for use with any Betts hydraulically operated valve or vent.
- 2.2 The pump head and internal parts are made of corrosion resistant stainless steel. The reservoir is made of aluminum with a durable E-coating.
- 2.3 The pump head can be replaced without unbolting the reservoir from its mounting.
- 2.4 ¼ NPT hydraulic connections are conveniently located at both the front of the pump and on the right side. A drain plug allows the reservoir to be drained without unbolting the pump.
- 2.5 Pump can be mounted horizontally or vertically with outlet end down.
- 2.6 The pump contains a tamper resistant pressure relief set to bypass at approximately 3,000 psi [207 bar] and is non-adjustable to prevent dangerous over-pressure conditions.
- 2.7 A complete information page can be found in our catalog Section 35 Page 3D & 3E. Also available is a wall chart showing all parts; chart number 5VHP01.

3.0 Installation

- 3.1 Betts Industries recommends that the hydraulic hand pump not be painted. If pump is painted, care must be taken to prevent any paint on the piston (1) and entering the system thru the piston seal (21).
- 3.2 Small particles of thread tape or paste that are loose in the hydraulic system can lodge under the sealing balls in the pump and render the pump inoperative. Care must be taken to ensure tape or paste is not applied to the first two threads of the outlet (24) or any fittings.
- 3.3 Mounting:
 - 3.3.1 Securely mount pump by bolting through the 4 holes in the mounting flanges at the bottom of the reservoir (30).
 - 3.3.2 Allow sufficient clearance for the pump handle (16) and to allow the pressure release handle (4) to swing.
 - 3.3.3 Hydraulic lines must be rated for a minimum of 5000 psi burst pressure and may be plumbed to the front of the pump and/or the right side of the pump. If hydraulic lines are to be only mounted to the right side of the pump, remove plug (11) from auxiliary outlet port and install it into primary outlet (24) on valve block (7).
 - 3.3.4 To mount pump vertically, remove drain plug (29) and vent plug (35). Reinstall drain plug (29) in cover plate (33) and reinstall vent plug (35) at end of reservoir (30).
 - Pump must be mounted with outlet end down.
 - 3.3.5 Be sure that all fittings, lines and the reservoir (30) are clean and free of dirt, filings and debris. Most hydraulic failures can be attributed to foreign material in the hydraulic system.

- 3.4 Filling and Priming: Pumps are shipped dry and must be filled and primed before use.
- 3.4.1 Be sure that all hydraulic vapor vents and hydraulic valves are closed before filling reservoir (30).
- 3.4.2 Remove vent plug (35) and fill reservoir (30) to within ¼" of cover plate (33) with fluid.

**High Pressure is Dangerous:**

Use properly rated lines and fittings. Ensure all air is bled from the system and all fittings are secure. Failure to take these precautions could result in serious injury or death.

- 3.4.3 Prime pump by rotating the pressure release handle (4) counterclockwise to the open position and pumping slowly at least 10 full strokes.
- 3.4.4 If pump does not prime:
- Rotate pressure release handle (4) counterclockwise to open position.
 - Ensure top of pump and piston (1) are clean and free of debris.
 - Remove e-clip (19), clevis pin (18) and piston (1).
 - ½ fill piston cavity with fluid (same as in reservoir).
 - Replace piston (1) and reinstall clevis pin (18) and e-clip (19).
 - Slowly pump at least 10 full strokes pausing for a couple of seconds at the bottom of each stroke to allow air to bleed out of the valve block (7).
- 3.4.5 All air must be bled from the entire length of the hydraulic lines at the point of connection to all hydraulically operated vents, valves or fusible/frangible.
- 3.4.6 Open and close all valves and vents a minimum of 3 times.
- 3.4.7 Rotate the pressure release handle (4) counterclockwise to the open positions and inspect all valves and vent to be sure they are fully closed.
- 3.4.8 Check fluid level, top off if necessary and reinstall vent plug (35).
- 3.5 Once a year pumps should be drained and reservoir (30) thoroughly cleaned. Use only clean new fluid to refill the reservoir (30)

4.0 Inspection and Testing

- 4.1 The pump should be tested for leaks once installed, filled and primed:
 - 4.1.1 Close pressure release handle (4) and actuate pump handle until all hydraulic vapor vents and hydraulic valves have been opened.
 - 4.1.2 Maintain hydraulic pressure for 5 minutes.
 - 4.1.3 Check all hydraulic lines, fittings, vapor vents and valves for signs of leakage.
 - 4.1.4 Check for leakage from the auxiliary outlet plug (11), primary outlet (24) or between the valve block (7) and the reservoir (30).
 - 4.1.5 Pump reservoir (30) should not require continual filling. This is a sign there is a leak in the system and the leak must be repaired.



All Hydraulic Leaks Require Repair:

If hydraulic system loses pressure and an external leak cannot be found, all vapor vents and valves must be inspected and repaired. Failure to repair leaking vents or valves could result in damage to equipment, tank or contamination of the load.

5.0 Disassembly and Rebuild Instructions

- 5.1 A repair kit is available to rebuild the hydraulic pump HP46982ALSL or HP4682SL. The part number for the kit is HP75359SL and it includes items – 1,2,6,8,12,21,23,27,28,34
- 5.2 Replacement of cover gasket (34): See Figure 2
 - 5.2.1 Remove 4 cover cap screws (32).
 - 5.2.2 Remove cover plate (33) and peel off old cover gasket (34).
 - 5.2.3 Ensure Sealing surfaces of the reservoir (30) and cover plate (33) are free of damage or debris.
 - 5.2.4 Install new cover gasket (34), cover (33) and cover cap screws (32). Torque cover cap screws (32) to approximately 15 ft-lbs.

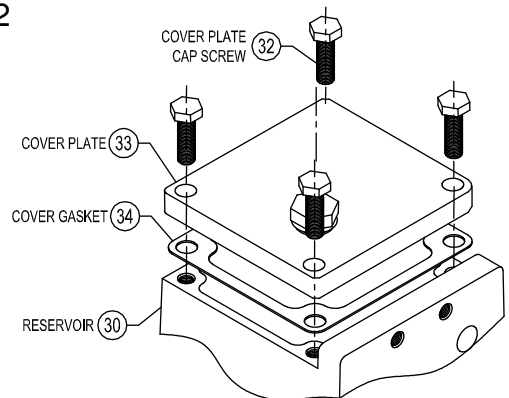
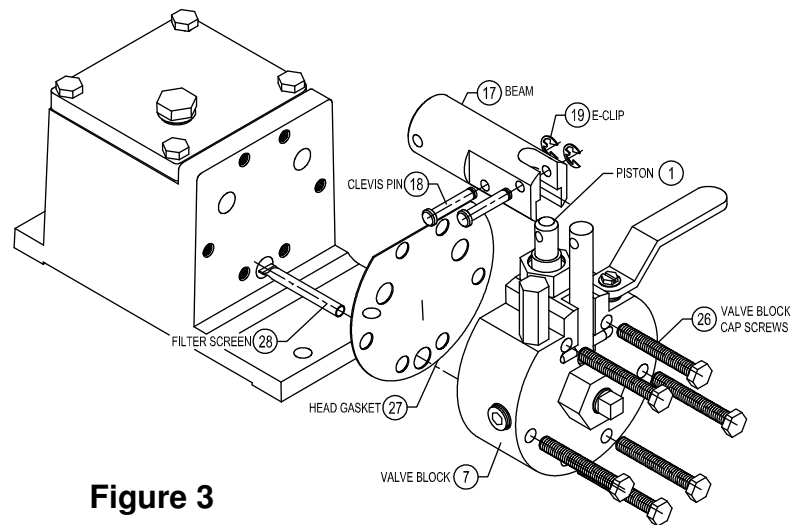

Figure 2

- 5.3 Replacement of head gasket (27) and/or filter screen (28): See Figure 3
- 5.3.1 Remove e-clip (19) and clevis pin (18) from piston (1) and beam (17).
- 5.3.2 Remove 6 valve block cap screws (26) and carefully pull valve block (7) and head gasket (27) from reservoir. Filter screen (28) should come out with valve block.
- 5.3.3 If filter screen (28) is stuck in reservoir, remove cover plate (33); see section 5.2.
- 5.3.4 Carefully insert new filter screen (28) into bottom hole on valve block (7).
- 5.3.5 Replace top 2 valve block cap screws (26) into valve block (7) and hang new head gasket (27) on these cap screws.
- 5.3.6 Carefully position valve block (7) so filter screen (28) fits into appropriate hole in reservoir (30) and hand tighten the 2 valve block cap screws (26) into reservoir (30).
- 5.3.7 Replace remaining valve block cap screws (26) and torque in a star pattern to 18-20 ft-lbs.

**Figure 3**

5.4 Replacement of piston (1), piston seal (21), and \varnothing .313 ball (8) under piston:
See Figure 4

5.4.1 Remove e-clip (19) and clevis pin (18) from piston (1) only and swing beam (17) out of the way.

5.4.2 Clean debris from area where piston (1) meets bushing/wiper (2) and remove piston (1).

5.4.3 Remove bushing/wiper (2), piston seal (21), spring retainer (10), ball spring (9) and \varnothing .313 ball (8).

5.4.4 Inspect wiper and replace bushing/wiper (2) if wiper is damaged or missing.

5.4.5 Discard old piston seal (21) and \varnothing .313 ball (8).

5.4.6 Check ball seat in bore of valve block (7) for damage or debris.

5.4.7 Install new \varnothing .313 ball (8). Replace ball spring (9) and spring retainer (10).

5.4.8 Inspect piston seal area in valve block (7) and remove any dirt or debris.

- Do not damage the sealing surface.

5.4.9 Install new piston seal (21) and apply removable thread lock to threads of bushing/wiper (2) and reinstall. Torque bushing/wiper (2) to approximately 15 ft-lbs.

5.4.10 Inspect piston (1) for damage, dents, scratches, etc. Replace if necessary.

5.4.11 Inspect piston cavity in valve block (7) and remove any debris

5.4.12 Half fill piston cavity with fluid (same as in reservoir).

5.4.13 Replace piston (1) and reinstall clevis pin (18) and e-clip (19).

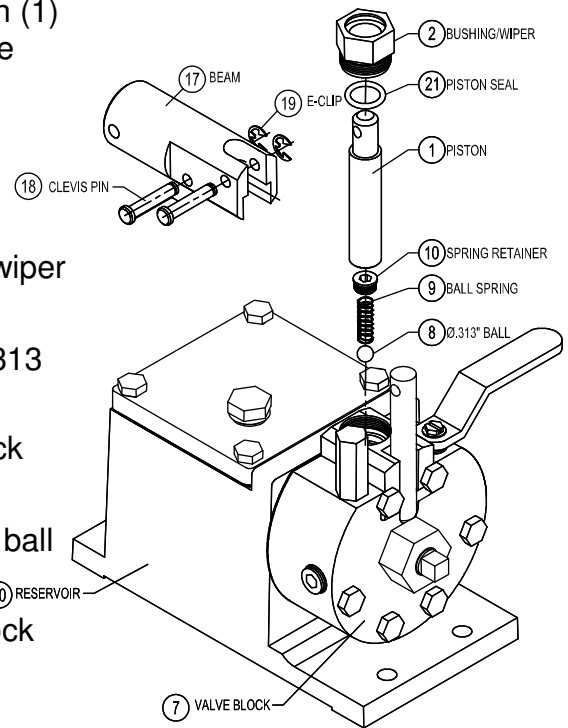
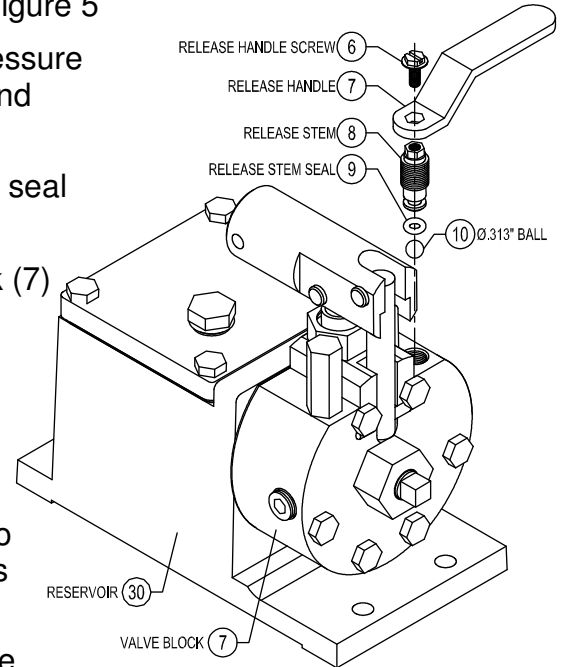

Figure 4

5.5 Replacement of release stem seal (6): See Figure 5

- 5.5.1 Remove release handle screw (3), pressure release handle (4), release stem (5) and $\varnothing.313$ ball (8).
- 5.5.2 Remove and discard old release stem seal (6) and discard old $\varnothing.313$ ball (8).
- 5.5.3 Inspect ball seat in bore of valve block (7) for damage or debris.
- 5.5.4 Install new $\varnothing.313$ ball (8) and release stem (5) with new release stem seal (6) installed. Tighten release stem (5) to approximately 15 ft-lbs.
- 5.5.5 Position pressure release handle (4) to be in recommended closed position as shown in Figure 5.
- 5.5.6 Apply removable thread lock to release handle screw (3) and torque to approximately 15 ft-lbs.

**Figure 5****5.6 Replacement of $\varnothing.188$ ball (12) under pressure release: See Figure 6**

- 5.6.1 Remove bypass cap (15), bypass spring (14), bypass plug (13) and $\varnothing.188$ ball (12). Discard $\varnothing.188$ ball (12).
- 5.6.2 Inspect bypass cap (15) for damage or cracks at base of threads and replace if necessary.
- 5.6.3 Be sure that bypass spring (14) moves freely in bypass cap (15). Replace if necessary.
- 5.6.4 Inspect ball seat in bore of valve block (7) for damage or debris.
- 5.6.5 Install new $\varnothing.188$ ball (12), bypass plug (13), bypass spring (14) and bypass cap (15). Torque bypass cap (15) to approximately 15 ft-lbs. Do not over tighten.

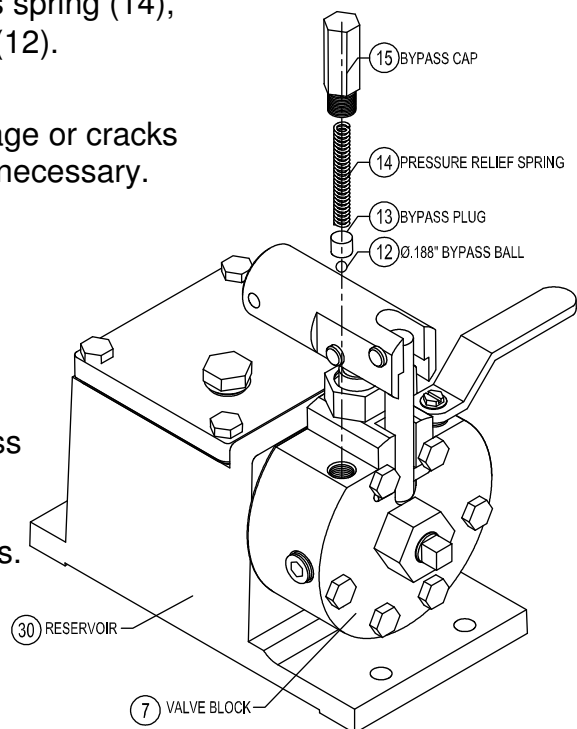
**Figure 6**

- 5.7 Replacement of outlet (24), outlet o-ring (23) and $\varnothing.313$ ball (8): See Figure 7
- 5.7.1 Disconnect pump from hydraulic system.
- 5.7.2 Remove outlet (24), outlet o-ring (23), ball spring (9) and $\varnothing.313$ ball (8). Discard outlet o-ring (23), $\varnothing.313$ ball (8).
- 5.7.3 Inspect ball spring (9) for damage and replace if necessary.
- 5.7.4 Clean valve block (7) area around outlet (24).
- 5.7.5 Inspect ball seat in bore of valve block (7) for damage or debris.
- 5.7.6 Place new $\varnothing.313$ ball (8) into valve block (7).
- 5.7.7 Install outlet o-ring (23) and ball spring (9) into outlet (24) and carefully hand tighten outlet into valve block (7).
- Care must be taken to be sure the $\varnothing.313$ ball (8) does not get tangled in the ball spring (9).
 - Care must be taken to ensure the outlet o-ring (23) is in its groove when outlet (24) is fully tightened to valve block
- 5.7.8 If working with the older version of the outlet (75232BR) and washer (9Z6185), do not use outlet o-ring (23), replace the washer with the new version of the washer (9Z6197).
- It is recommended to upgrade to the new version of the outlet (24) and outlet o-ring (23) as it is an improved design.
- 5.7.9 Torque outlet (24) to 20-25 ft-lbs.

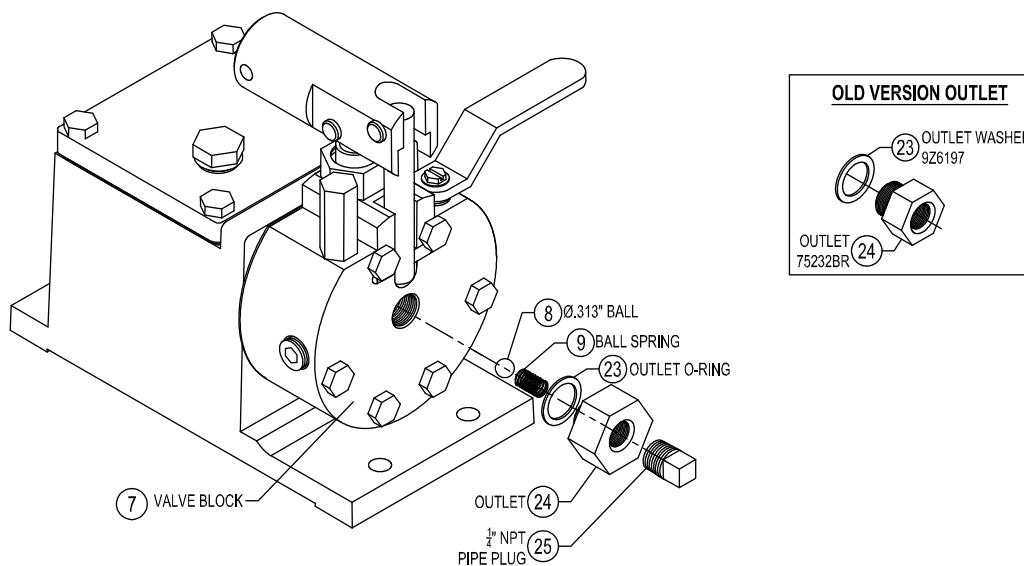
**Figure 7**

SEE TROUBLE SHOOTING GUIDE ON PAGE 11

6.0 Troubleshooting Guide

NOTE: MOST HYDRAULIC FAILURES CAN BE ATTRIBUTED TO THE PRESENCE OF DIRT OR FOREIGN MATERIAL IN THE HYDRAULIC SYSTEM. IT IS IMPERATIVE THAT ALL COMPONENTS ARE CLEAN AND ONLY NEW, CLEAN FLUID IS USED.

Problem	Cause	Solution
Leaking auxiliary outlet plug (11)	Auxiliary outlet plug (11) loose	Tighten auxiliary outlet plug (11) to eliminate leak.
Leaking under outlet plug (24).	Missing or damaged outlet o-ring (23) (older versions may use washer).	Replace O-ring (or washer). If problem persists and outlet is older style with flat washer, replace outlet and washer with new style outlet (75583BR) and outlet o-ring (75584BN).
Leaking between valve block (7) and reservoir (30)	Loose valve block cap screws (26)	Tighten cap screws (26) to 18-24 ft-lbs. If problem persists, replace head gasket (27). See Section 5.2
Leaking from piston (1) and bushing/wiper (2)	Piston seal o-ring (21) damaged or worn out. Damaged or worn piston (1).	Replace piston seal o-ring (21), piston (1) or bushing/wiper (2). See Section 5.3
Leaking from bypass cap (15)	Loose or broken bypass cap (15)	Check to be sure bypass cap (15) is tight. DO NOT over tighten. Inspect bypass cap (15) for damage or crack at thread transition. If damaged, replace. See Section 5.5
Leaking from release stem (5)	Damaged or missing release stem seal (6)	Replace release stem seal (6). See Section 5.4
Pump fails to build or hold pressure	Low hydraulic fluid level in reservoir (30).	Check hydraulic fluid level. NOTE: If level continues to drop, problem could be with vent, valve or a leak in the hydraulic line.



All Hydraulic Leaks Require Repair:

If hydraulic system losses pressure and an external leak cannot be found, all vapor vents and valves must be inspected and repaired. Failure to repair leaking vents or valves could result in damage to equipment, tank or contamination of the load.

Pump fails to build or hold pressure (continued)	Air trapped in system.	All air must be bled from the entire length of the hydraulic lines at the point of connection to all hydraulically operated vents, valves or fusible/frangible.
	Valve block (7) contaminated with dirt, debris or chips.	Flush valve block (7) to be sure all debris is removed.
	Filter screen (28) is clogged.	Replace filter screen (28). See Section 5.2
	Missing or damaged Ø.313 ball (8) from outlet (24)	Replace Ø.313 ball (8). See Section 5.6
	Missing or damaged Ø.313 ball (8) under pressure release handle (4)	Replace Ø.313 ball (8). See Section 5.4
	Missing or damaged Ø.313 ball (8) under piston (1)	Replace Ø.313 ball (8). See Section 5.3
	Missing or damaged Ø.188 ball (12) under bypass cap (15) or missing or damaged bypass spring (14)	Replace Ø.188 ball (12) and or bypass spring (14). See Section 5.5
	Ice or frozen fluid in system.	Remove fluid and flush entire reservoir and valve block. Replace fluid with appropriate mixture for operating temperatures